



# URBAN DESIGN AND ARCHITECTURAL GUIDELINES

*for* THE HERNDON TRANSIT-ORIENTED CORE

URBAN DESIGN ASSOCIATES





**PREPARED BY**

Urban Design Associates  
*Pittsburgh, Pennsylvania*

**PREPARED FOR**

The Town of Herndon  
*777 Lynn Street  
P. O. Box 427  
Herndon, VA 22070*

Department of Community  
Development:  
*703-787-7380*

**TOWN COUNCIL**

Lisa C. Merkel, *Mayor*  
Connie Haines Hutchinson, *Vice Mayor*  
C. Melissa Jonas  
David A. Kirby  
Sheila A. Olem  
Charlie D. Waddell  
Grace H. Wolf

**ARCHITECTURAL REVIEW BOARD**

Robert B. Walker, *Chair*  
Meghan Ulrich, *Vice Chair*  
William Hilder  
Tim J. Lovett  
Cari Lyn B. Pierce

**PLANNING COMMISSION**

Kevin J. East, *Chair*  
Paul LaReche, *Vice Chair*  
Bernadette Bettard  
Robert Burk  
George Burke  
Kevin G. Moses  
Sean Regan

**TOWN STAFF**

Arthur A. Anselene, *Town Manager*  
Elizabeth M. Gilleran, *Director of Community Development*  
Raymond P Ocel, Jr., *Development Program Planner*  
Bryce Perry, *Planner*  
Kay Robertson, *Senior Project Planner*

## TABLE OF CONTENTS

### SECTION A: INTRODUCTION

OVERVIEW	2
Purpose of the Guidelines	4
Herndon Transit-Oriented Core Plan	6
How To Use These Design Guidelines	8

### SECTION B: URBAN DESIGN PRINCIPLES

OVERVIEW	14
Build Connectivity	16
Essential Connections	17
Herndon Parkway	18
Herndon Promenade	20
Worldgate Drive Extension	22
Dulles Toll Road Frontage	23
Shared Private Access Drives	24
Mid-block Passages	25
Open Space and Trails	26
Van Buren Street	27

### SECTION C: ARCHITECTURAL GUIDELINES

OVERVIEW	30
Building Forms	32
Massing and Skyline	34
Mid-Rise and Podium Buildings	36
Tower Buildings	38
Parking	40
Phased Parking	42
Special Architectural Elements	44
Storefronts	48
Storefront Materials	50
Exterior Amenity Zones	51
Materials	52
Suggested Materials	53
Green Roofs	54

## **SECTION D: LANDSCAPING GUIDELINES**

To be added at the Town’s request at a later date	58
---	----

## **SECTION E: SUSTAINABILITY**

OVERVIEW	62
Green Roofs	64
Building Orientation	64
Natural Light and Ventilation	65
Local and Recycled Materials	65
Storm Water Systems	66

## **SECTION F: SAFETY AND SECURITY**

OVERVIEW	70
Safety and Security: CPTED Principles	71

## **SECTION G: INTERIM CONDITIONS AND PHASING OF DEVELOPMENT**

OVERVIEW	74
Interim Connectivity and Streetscape	75
Open Spaces	77
Interim Building Design	79
Storm Water Management	80
Construction and Staging	81

## **SECTION H: SIGNAGE GUIDELINES**

To be added at the Town’s request at a later date	84
---	----

## **SECTION I: GLOSSARY**

## **APPENDIX: SOLAR STUDIES**

SECTION A

INTRODUCTION

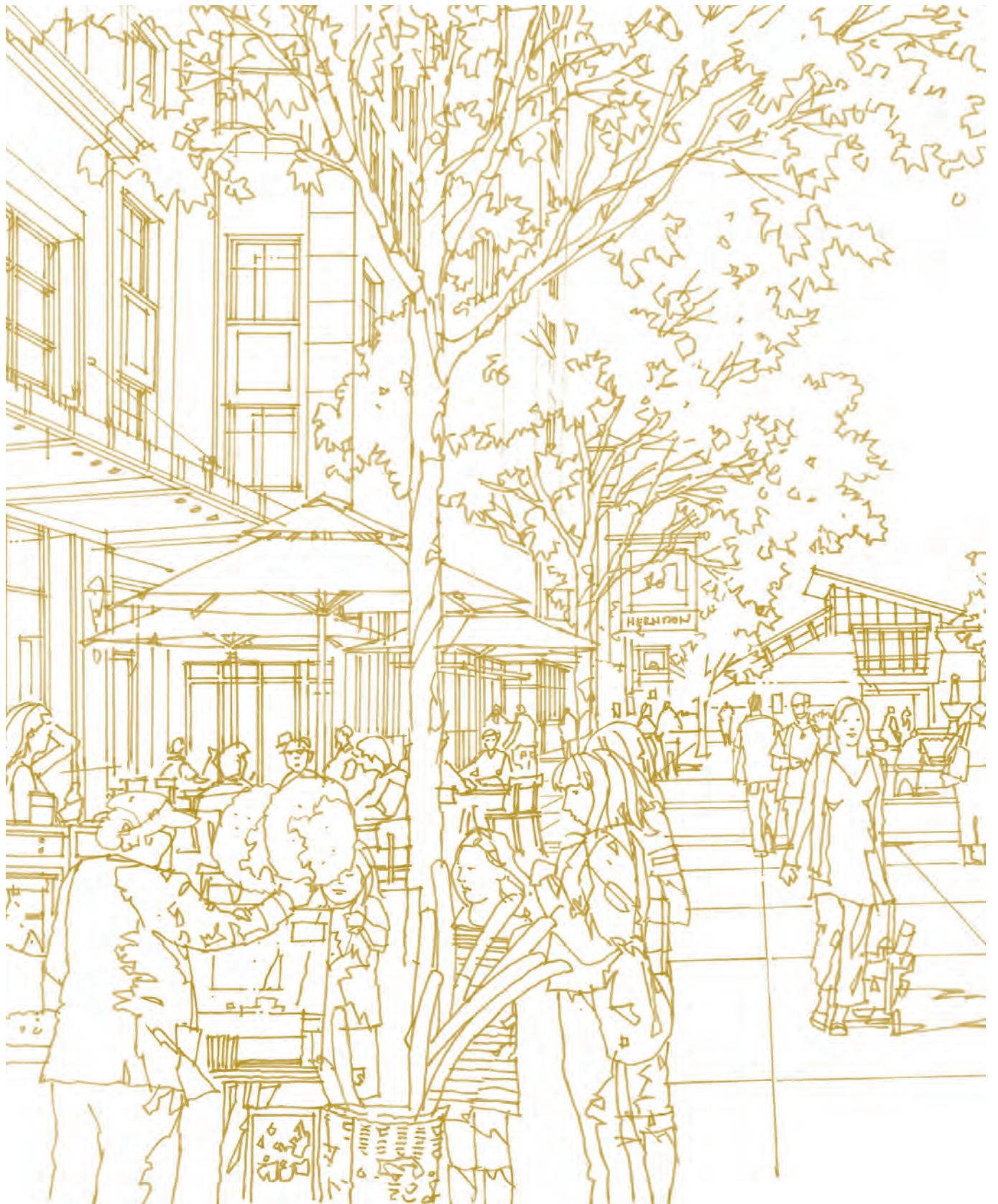

# OVERVIEW

These Guidelines provide assistance to developers and property owners proposing to redevelop their lands, and to Town decision-makers, in accordance with the Herndon Transit-Oriented Core (HTOC) Plan adopted by the Town of Herndon on February 28, 2012. The Guidelines will assist the Town Council, Planning Commission, Architectural Review Board, and Town Staff in the evaluation of development proposals.

- » The Guidelines are not a stand-alone document but should be read and applied in conjunction with the Comprehensive Plan, including the Herndon Metro Station Area Study, and the appropriate sections of the Herndon Zoning Ordinance.
- » The Guidelines are not intended to limit creativity and innovation but rather to illustrate principles described in the Comprehensive Plan and to inform the creative process.
- » The HTOC Plan sets forth the Town's objectives and the general character for the new transit-oriented development. The HTOC is to be developed with beautiful public spaces, active uses, pedestrian enhancement, and inspirational architecture. The Guidelines build on the design principles articulated in the HTOC Plan.
- » The Guidelines help realize the vision for the HTOC with an active public realm that is inviting to all citizens, not a series of private buildings without a sense of community and place.



- » The Guidelines attempt to balance multiple scales of development ranging from a traditional Town scale (low rise, smaller buildings) to the scale of development emerging elsewhere along the Dulles Toll Road (mid-to-high-rise, sometimes monolithic).
- » The compatibility of the Transit-Oriented Core with the Town will depend on the quality of the streets, trails, public spaces, private spaces, private access and circulation to and within the Transit-Oriented Core, all qualities that distinguish Herndon from other places in Fairfax County.

*(Below) Illustrative perspective view characterizing the future Herndon promenade*



## Purpose of the Guidelines

The Design Guidelines for the Herndon Transit-Oriented Core are meant to be used in conjunction with the Herndon 2030 Comprehensive Plan, the Zoning Ordinance, the Herndon Public Facilities Manual, and all other applicable Town policies. Nothing in the Design Guidelines is intended to justify or enable deviation from any regulation governing the development of land.

The Design Guidelines for the HTOC provide guidance for the design of public spaces, buildings, and private access ways. The Guidelines are a tool to guide redevelopment proposals by articulating expectations of the Town Council for the quality and type of redevelopment. However, the Guidelines are not exclusive. Any redevelopment proposal that strives for excellence in design, quality of materials, and superior public spaces will be evaluated by the Town for the proposal's own merit.

Instances where a proposal differs significantly from the Guidelines should be justified in a way that is clear and understandable to the general public. The justification should be based on objective information that is not confined to descriptive language. Examples of proposals that would differ “significantly” from the Guidelines include but are not limited to:

1. Preferred heights of buildings along Herndon Parkway and along the Dulles Toll Road.
2. Inappropriate locations of private access drive intersections on Herndon Parkway.
3. Reduction in the standards for streetscape.

Not all proposals that differ significantly from the guidelines will be able to be justified, therefore, the proposal will be required to be modified to bring in into compliance with the guidelines.



*Herndon Metro Station Area, 2013*

# Herndon Transit-Oriented Core Plan

The Herndon Transit-Oriented Core (HTOC) Plan as adopted by the Town Council is the result of an extensive community planning process that arrived at a vision for new transit-oriented development. This development is made largely in part by construction of the Dulles Corridor Metrorail Project and the planned Herndon Station. The Metro station and transit platform will be located within the median of the Toll Road and will be connected in Herndon to the north side entry pavilion with a pedestrian bridge. The HTOC Plan allocates space for a pedestrian promenade that will lead the north side entry pavilion to Herndon Parkway. This promenade is the core of the proposed community and will become an active retail, restaurant and entertainment spine. Herndon's station area will be very different from other stations along the Silver Line by introducing visitors to a car free public space. A representative list of public and private spaces is elaborated upon beginning on page 117 of the Herndon Metro Station Area Study, Chapter 6 – Transit-Oriented Core Plan. Construction of new public space, infrastructure and development will occur mostly on private land. The HTOC Plan has built in flexibility to allow developers to collaborate in creative ways that may result in different open spaces and urban patterns than shown in the Comprehensive Plan. Applying the Guidelines and collaboration between neighboring developments is critical in helping create successful transit-oriented development.



## REFERENCE MATERIAL

- » Herndon Metro Station Area Plan: [http://www.herndon-va.gov/content/zoning/planningandzoning/metrorail\\_planning/metrostudychapter6.pdf](http://www.herndon-va.gov/content/zoning/planningandzoning/metrorail_planning/metrostudychapter6.pdf)



*Illustrative Plan, Herndon Metro Station Area Study, Herndon 2030 Comprehensive Plan Amendment, Adopted February 28, 2012.*

# How To Use These Design Guidelines

These Guidelines are intended to provide advice for new development within the HTOC core in a manner that is consistent with the Town's vision. The site context, site characteristics, and development objectives will influence a series of decisions related to siting of buildings, parking strategies, building types, open space design, and architectural styles. The Guidelines are intended as a companion document to the Town codes and are a tool to visually articulate the expectations for development form and quality. In coordination with the principles and guidelines expressed in the Herndon Metrorail Station Comprehensive Plan Amendment adopted in February 2012, consider the following steps when designing a specific site.

## STEP 1: URBAN DESIGN PRINCIPLES

- » Review the floor area ratio of surrounding properties and any public space or infrastructure planned or in place on adjacent properties.
- » Understand the desired level of pedestrian and vehicular connectivity in the HTOC and how that connectivity relates to the site.
- » Determine the open space and pedestrian connectivity expectations for the site.
- » Within this document, review the massing studies for advice on placement of buildings, skyline, building shadows, and scale.
- » Within this document, review the height diagrams for advice about varying the height of the proposed building(s).
- » Incorporate sustainability, safety and security, landscaping, signage and other guidelines as appropriate on the development plan.
- » For phased development, refer to Section H, Phasing of Redevelopment
- » Multiple parcels submitted as part of a unified site plan or development plan application shall constitute a single land bay or property when applying the requirements of the guidelines and Article VIII, Planned development transit-oriented core (PD-TOC), including but not limited to the distribution of density and interior recreational and non-recreational open space.

## STEP 2: PUBLIC PLACES

Public places are any space intended for public use, including but not limited to: public and private vehicular routes, building lobbies, pedestrian connec-

*Step 1: The HTOC Plan sets forth the Town's objectives and the general character for the new transit-oriented district.*



tions; also, site amenities designed to be publicly accessible such as certain green space, recreation amenities, or parking areas can be included. Public places are not restricted to publicly-owned property and are likely sometimes to overlap with amenities provided on private property.

- » Understand the character of public spaces articulated in the adopted plan as well as those that will be created.
- » After determining the open space and pedestrian connectivity expectations for the site in Step 1, identify the optimal locations on the development site for these features based on the uses proposed and development plans for adjacent properties.
- » The design of the series of unique but interrelated spaces described in the HTOC Plan is crucial in creating an area of distinctive character.
- » Consider using parking structures to facilitate pedestrian public access across sites and from site to site. Provide walkways separate from drive lanes, unless interparcel pedestrian access is provided in another manner (e.g., ground level sidewalk connections).
- » Locate parking structure vehicular entrances so that they disrupt the surrounding pedestrian public environment as little as possible and provide separate pedestrian entrances to the structures.
- » Identify which nearby areas are likely to be influenced by the site's development and seek to fulfill the objectives of the Town for the public realm, including distinctive character, connectivity, relaxation, exercise, minor entertainment venues, civic pursuits and social engagement.
- » Ensure that service amenities such as loading docks, dumpsters, grease barrels, trash compactors, electric boxes, and generators are accommodated in bays or recessed within the building envelope and that service vehicles can access the bays. Sites in the HTOC are likely to have public visibility on all sides, so screening and ornamental gates or service bay doors are of paramount importance.
- » Public places can help define key addresses in the HTOC. Literally, consider what type of street address will appeal to a corporate tenant if the building does not front on Herndon Parkway. Through the site design process, a "presence" can be created for an appealing address.

*Step 2: Consider the guidelines for building design regarding massing, composition, and materials*

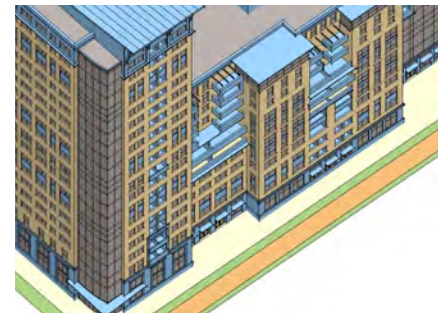
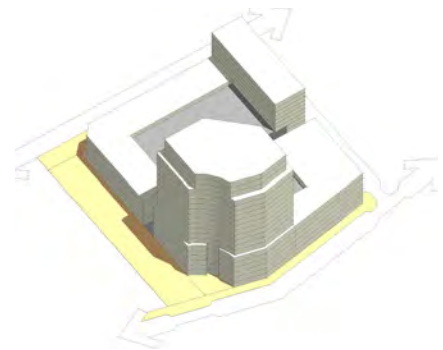

### STEP 3: PRIVATE SPACES

Private spaces are reserved for use by site tenants and visitors only and never overlap with publicly-owned property or privately-owned amenities accessible to the public. Private spaces include site amenities such as green space that is not publicly accessible or certain recreation amenities. After public places are defined on a schematic plan, private spaces can be explored.

- » Distinguish the site amenities that will not be available for public use. Identify the locations, the type of open space involved, and appropriate on-site recreation uses for private use by site tenants.
- » Private spaces can be part of the design of the series of unique but inter-related spaces described in the HTOC Plan when they serve as a visual amenity that can be seen beyond the site boundary.
- » Private recreation amenities can be located either indoors or outdoors.
- » Parking areas can be considered a private space when they are not offered for general public use and have secure entrances. These areas should be located discreetly so that public parking areas have less visibility.
- » Visible parking and parking lots are not appropriate at final build out of the property.



*Step 3: Perspectives help understand key addresses in the district*



## STEP 4: ARCHITECTURAL GUIDELINES

- » Prepare a plan of development for the site, thinking of it as the creation of a new land bay. Consider development phasing, access, uses, and massing. See Section G of this document for more information about phasing.
- » Development in the HTOC will be composed of mid-level structures and towers, and may incorporate podiums.
- » Determine the proposed building form (mid-level structure, tower, parking garage) and review the advice in this document for that type.
- » Refer to information about Special Architectural Elements under Section C, Architectural Guidelines, in this document when designing the facade.
- » For buildings with a commercial ground floor, refer to information about Exterior Amenity Zones under Section C, Architectural Guidelines, in this document.



*Step 4: Architectural Guidelines — as this sample spread shows — guide the development plan of the site*

SECTION B

URBAN DESIGN PRINCIPLES



# OVERVIEW

The HTOC Plan describes the Town’s vision for a new transit served community that will replace lower density auto-oriented commercial development along Herndon Parkway. The area is located on a series of privately owned parcels, and its future success will depend on the participation and cooperation of private landowners and their developers. In order to create a mixed-use pedestrian friendly community, this area must transition from independent developments on lots fronting Herndon Parkway to a series of connected land bays featuring a new network of multi-modal linkages forming a walkable community and supporting transportation alternatives including walking, biking and mass transit. The connections are a large part of the public space of the area even though some of the connections may be privately owned. A network of connections will help reduce reliance on Herndon Parkway for all vehicular movement and add vibrancy to the HTOC.

Each development proposal should contribute to the development of a cohesive transit-oriented core. Accordingly, the proposal should include an analysis of how any structure will fit with the aesthetic and functional vision of the core as expressed by these guidelines. To that end, each development proposal should identify the potential land bay in which it will be located and describe in detail the relationship of the proposed development to the development of the adjacent land bay including pedestrian connectivity, shared access points and parking, the orientation to the adjacent roadways and the development of open space and trails. Each development proposal should contribute to the overall architectural appeal of the district and, accordingly, should describe the relationship of the architectural style, height and materials as it relates to other existing redeveloped buildings in the district. In particular, the proposal should identify how it will contribute to a varied skyline in the district, the preferred building forms identified in these guidelines, and those special architectural elements that will result in it being an integrated part of the core. The proposal should identify, where applicable, any phased or shared

parking. Particular attention should be paid to the pedestrian experience as it relates to other buildings in the district, including setbacks, storefront composition, openings and transparency, awnings, storefront design, storefront materials and exteriors, amenity zones, landscaping, signage and building materials.

The structure of the area begins with the creation of land bays that can be defined by pedestrian ways and private access drives. Herndon Parkway, Van Buren Street and Worldgate Drive extended will be the primary streets carrying the majority of vehicular traffic. A supplemental network of connections will help provide a logical framework for pedestrian circulation and utility infrastructure as well as access to buildings, parking, and service areas. Thus, service areas and parking facilities can be shared and embedded in the land bays. The connections can be built incrementally to create a cohesive urban environment that is intelligible and user friendly to visitors and tenants. The success of this area will depend on commitment to, and participation by, the Town and property owners in building a remarkable transit served community.

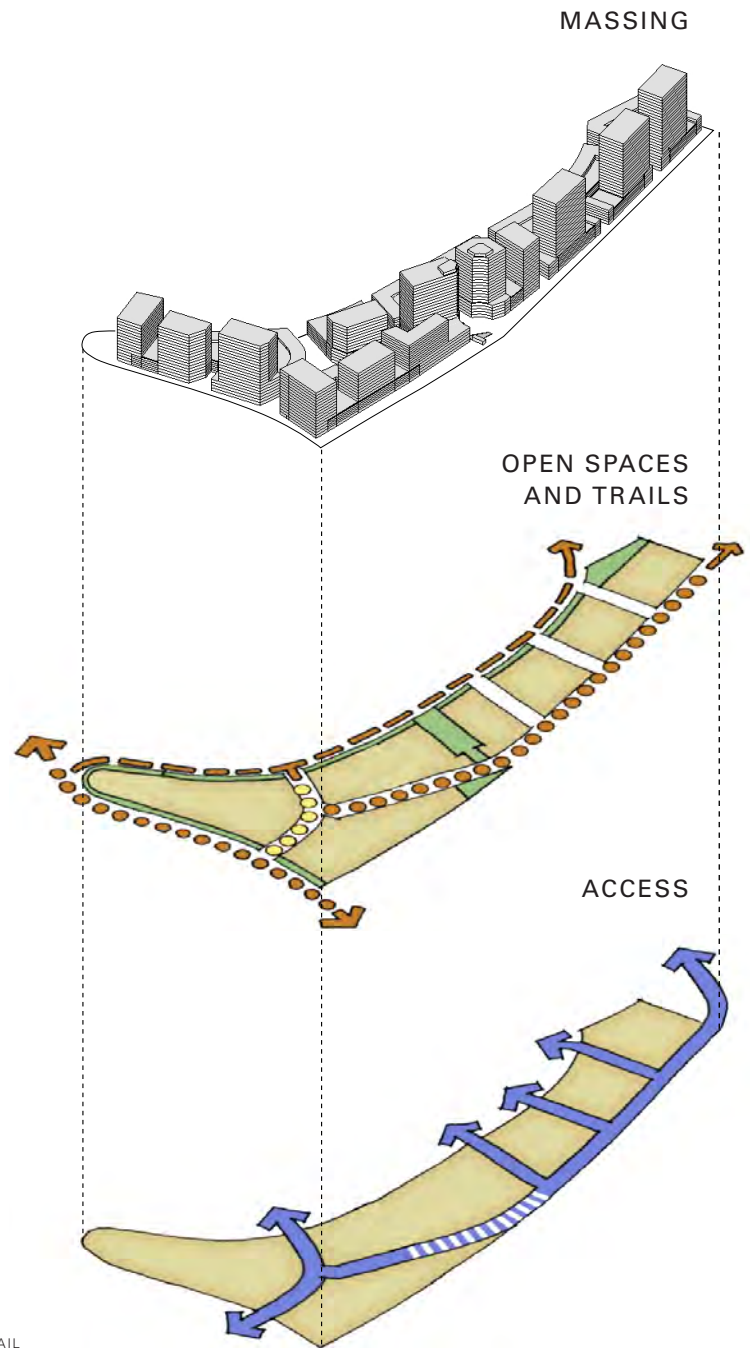

## Build Connectivity

The Town expressed a clear preference in the HTOC Plan for a pedestrian dominant public domain throughout the Metro Station area. Therefore, a network of clearly configured, walkable connections is important for providing public accessibility within the Herndon Metro Station Area. A variety of connection types provides opportunities for different frontages that will diversify the character and feel of the place. By providing the proper balance for parking, bicycles, pedestrians, sustainable landscaping, storm water management, and on-site vehicle movement, developers will make the Herndon Metro Station Area a successful and vibrant place for all users. The exact location of private pedestrian and vehicular connections will be determined by property owners in collaboration with the Town. Cooperation among property owners may result in creative alternatives for access and development configurations.

Developers are strongly encouraged to consider mid-block passages that facilitate movement across land bays for pedestrians. Developers may consider interconnected courtyards, retail courts, open or enclosed galleries and intimate lanes.

# Essential Connections

“Addresses” are defined by location on a street or access drive. Addresses also pertain to the relationship between the public and private realm and the treatment of streetscape and landscape. Because each parcel will likely be developed by a different entity, consideration for addresses can help guide developers on how the various parcels should relate to each other and to the public street or access drives they face. The addresses within the HTOC include:

- » Herndon Parkway
- » Herndon Promenade
- » Worldgate Drive Extension
- » Dulles Toll Road Frontage
- » Shared Private Access Drives
- » Mid-block Passages
- » Open Space and Trails
- » Van Buren Street

## HERNDON PARKWAY

Herndon Parkway is transformed into an elegant landscaped boulevard with multiple functions and is the primary approach to the Metro Station area. Currently designed as a parkway, the street will change in character between Van Buren Street and Exchange Place. This stretch will become more urban with wider sidewalks, more intersections, and urban landscape features and furnishings. A cycle track will be added to the southern side of Herndon Parkway and will connect to the local and regional trail network as described on page 105 of the Herndon Metro Station Area Study.

New intersections should be reserved exclusively for access drives that are shared by two or more properties. Service court and parking garage entries are not appropriate along Herndon Parkway. Intersections along Herndon Parkway for shared access drives generally should not be less than 300 feet apart. When they are separated by 700 feet or more, mid-block pedestrian passages should be considered.

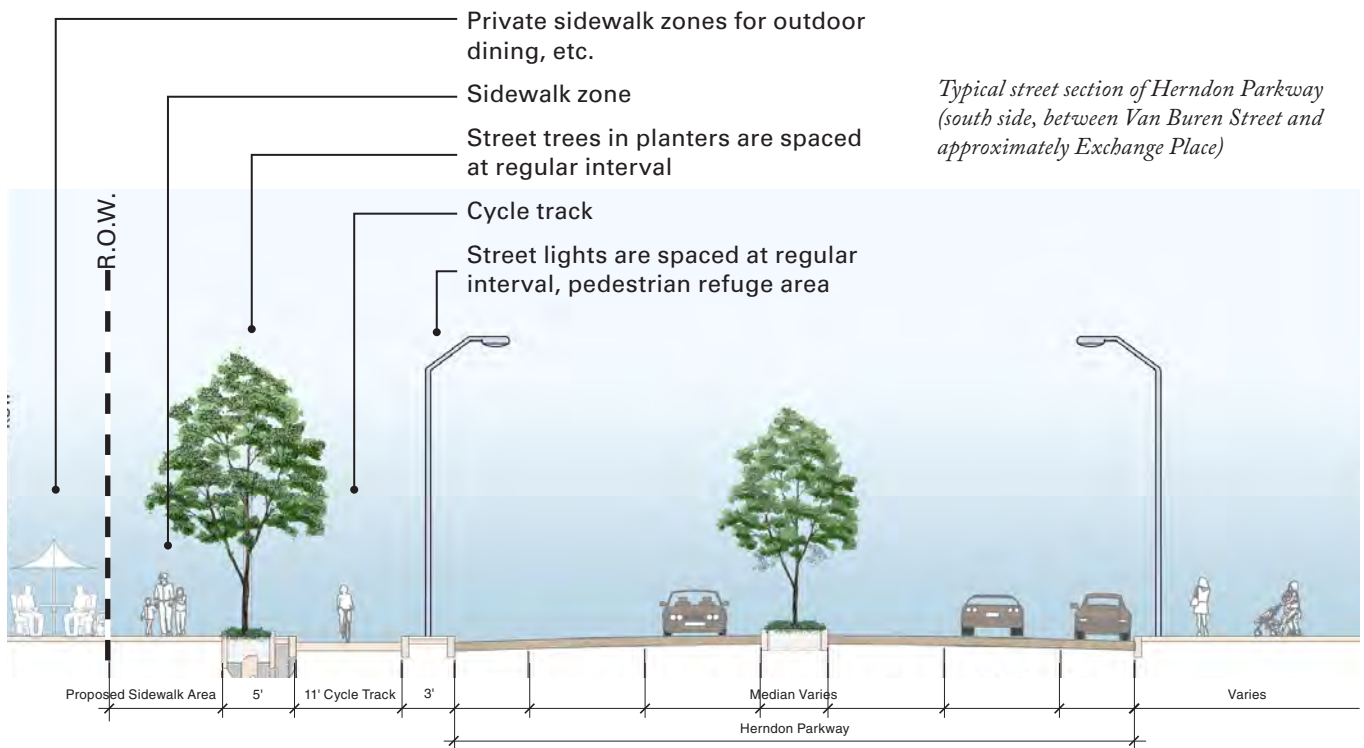





*(Left) Perspective view of Herndon Parkway*

### ESSENTIAL CHARACTERISTICS

- » Major gateway and approach to new district
- » Grand boulevard with median, wide sidewalks, and separated bikeway
- » Towers permitted in select locations
- » Little to no building setback
- » Ground floors reinforce the pedestrian-oriented environment and the amenity areas



## HERNDON PROMENADE

The Herndon Promenade is vibrant pedestrian space that connects Herndon Parkway to the Metro Station north side pavilion. The Promenade will be Metro Station area's primary pedestrian experience and main public space. For visitors arriving by transit, this will be the first impression people have of Herndon. It will be unique among all of the Metrorail transit stops and will immediately convey that Herndon is a pedestrian-friendly Town. The architecture of the Promenade should be scaled to be welcoming for pedestrians, and therefore articulated with great variety and lively details that impart quality and dignity. A monotony of duplicate storefronts or building entrances along the promenade should be avoided. The Promenade will feature generous landscaping and carefully designed areas for outdoor dining and vendors while maintaining a comfortable and convenient connection between the transit station and Herndon Parkway. In keeping with the sustainability objectives in this document, a well-designed pavilion with an easy to see green roof may be a way to add interest to the Promenade.



*Precedent of a well-designed pavilion*

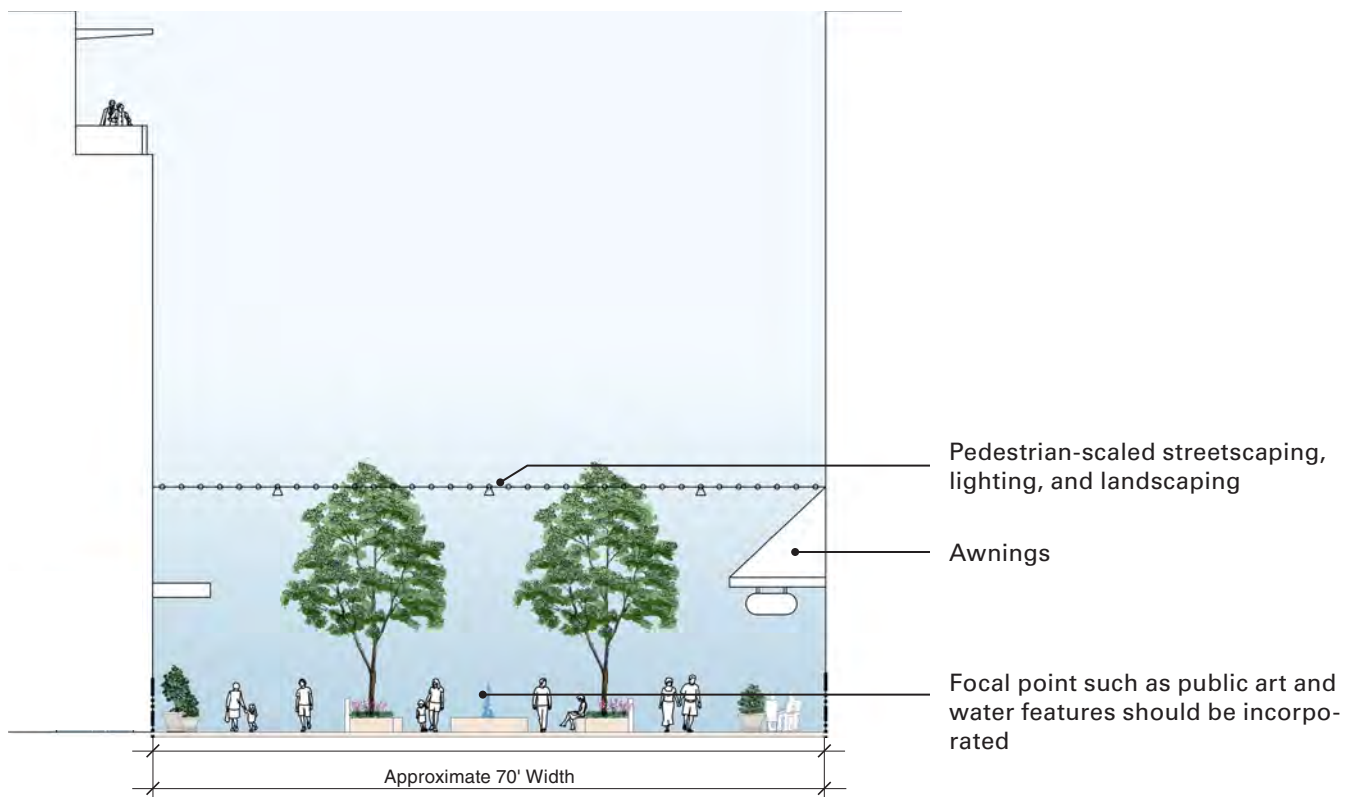

*Typical section of the Promenade*

Developers are encouraged to vary the width of the space to create areas for special landscape and activity features. In order to adequately create this space, the two properties adjacent to the promenade will each reserve a 35-foot wide space to create the 70-foot wide promenade. In all cases, a clear view of the transit station from Herndon Parkway is in keeping with the HTOC plan. Buildings should be massed to allow plentiful sunlight and should avoid the “canyon effect.” The Promenade will be lined with spaces attractive to active ground floor uses including shops, restaurants, and entertainment venues, and to a more limited extent the lobbies of office and residential towers.



*Perspective view of Herndon Promenade*

## WORLDGATE DRIVE EXTENSION

Worldgate Drive will be extended into the Metro Station area to connect to Herndon Parkway. New intersections with turn lanes will be built at Van Buren Street and Herndon Parkway. This street will be a major gateway into the HTOC and will provide access to several development parcels, despite its rather short length. This street will be an important front door to the HTOC and should be the location of building entrances and lobbies designed with a significant level of street transparency. This new street presents an opportunity for active store fronts and restaurants. The geometry of the street creates unique opportunities for urban plazas, landscaping, and public art. Buildings should be designed to address this street and take advantage of their high visibility. This street should be conceived as a unique urban space and defining place in the new transit-oriented community. Entries to service courts and parking garages may be permitted on a very limited basis but must be discreet.

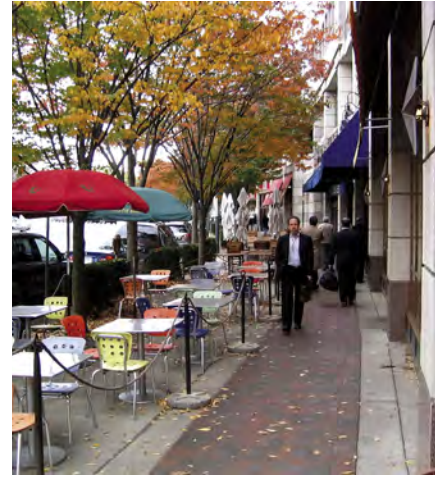

*Portions of the extension should support ground floor commercial uses*



*(Top) Example of a large scale corporate address (Left) Perspective view of Worldgate Drive Extension*

## DULLES TOLL ROAD FRONTAGE

The Dulles Toll Road frontage offers high visibility frontage for landmark buildings to announce their presence not only along the Dulles Corridor but also as having a distinctive location in the Town of Herndon. For the Metro Station area, the Dulles Toll Road frontage should command a different image than that facing Herndon Parkway and should not be regarded as the “back of the building” with lower quality façade design or an appropriate location for less attractive site amenities (such as unenclosed dumpsters and loading docks). One or more properties adjacent to the Metrorail Pavilion should consider providing handicapped access to the Metrorail facilities. Of primary importance is the provision of the regional Sugarland Run Stream Valley Trail connection between the eastern edge of the Herndon Transit-Oriented Core to the Metro Station entry pavilion and with Van Buren Street (also a designated regional trail location). To the east of the Metro Station, the trail should be incorporated into a 22 to 24 foot access drive that, as a secondary function, can serve emergency vehicles or even private automobiles if the owner elects. Surfaces and signage should indicate the primacy of the pedestrian and cyclist. The trail should be bordered to the south with a decorative fence, a minimum 8-foot wide landscape strip, and lighting, and to the north with an ADA appropriate sidewalk for when vehicles are present. The total width should be approximately 40 feet. No vehicle parking or loading zones should be permitted along the trail although drop-off zones can be designed to abut the trail and its auxiliary elements. In addition to the trail, an access drive (up to 22 feet in width) could be provided as needed to provide interparcel access on either side of the Metro Station entry pavilion. The area along the Dulles Toll Road frontage should be designed as an attractive linear park space with include prominent and distinctive elements including separate a trails for pedestrians and cyclists, lighting, attractive fencing along the Dulles Toll Road right-of-way boundary, and generous plantings.

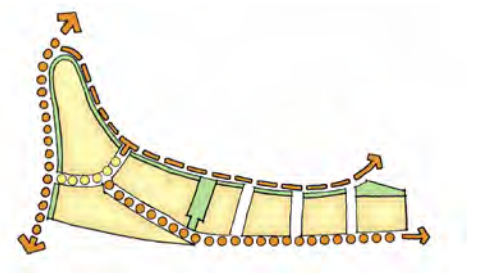

## SHARED PRIVATE ACCESS DRIVES

Shared private access drives provide access to development sites and can create interparcel connections. Access drives are built on private property, and adjoining property owners are encouraged to collaborate to locate, design and use access drives. The minimum width for these access drives is 38 feet to 40 feet. In the HTOC, private access drives are envisioned as local pedestrian-dominant drives that promote pedestrian access and motorized vehicles at slow speeds, while providing utility corridors, service access, emergency access, additional frontage, and access to parking facilities. Access drives are a crucial piece of the network of public space for pedestrians and cyclists. Therefore, the drives should present as welcoming and safe, with adequate lighting and natural surveillance. The Town would like to see private access drives designed with proper allocation of space for pedestrian and slow speed vehicular movement.



## MID-BLOCK PASSAGES

Mid-block passages are part of a network of beautiful public spaces and should be designed as such. They, too, can serve as corridors for underground utilities as needed. They are used only by pedestrians and bicyclists going at slow speed. They are routed through private developments to provide lateral movement from one site to the next. Generally, they should connect to streets, private access drives, or trails. Mid-block passages may be routed through parking garages only as a last resort when routing options are limited, and the on-site open space requirement has been met otherwise in an exemplary manner. Mid-block passages that are routed through parking garages should have dedicated pathways separate from vehicular travel ways.



## OPEN SPACE AND TRAILS

The open space network seeks to build upon the existing natural resources of Herndon in order to expand access to public open space through an interconnected system of parks and trails. This will be accomplished through the creation of open space and the addition of bicycle and pedestrian pathways both along and in addition to the existing street network. Types include:

- 1 Trails (generally, off-road passageways for pedestrians and bicyclists): Ensure that trail alignments outside of the Metro Station area are connected to pedestrian- and bicycle-friendly pathways in the Metro Station area. Provide pedestrian connections even where private access drives or private driveways may not connect.
- 2 Sidewalks: Provide lateral movements from one site to the next to allow connectivity. Discourage separate development parcels that have no relationship to one another.
- 3 Herndon Promenade (the dominant, image-making ground feature connecting the Metro Station entry pavilion to the Herndon Parkway): Provide access for pedestrian and bicycle movement
- 4 Urban Parks and Courtyards: Integrate new park spaces with private development. They may consist of courtyards, streetscape areas, green roofs, or as part of the linear Sugarland Run Stream Valley Park along the Dulles Toll Road frontage.
- 5 While outdoor open spaces are important, new development will also create interiors rich in public and private recreational spaces. Interior public spaces can include facilities such as publicly operated activity room and sports training facilities.

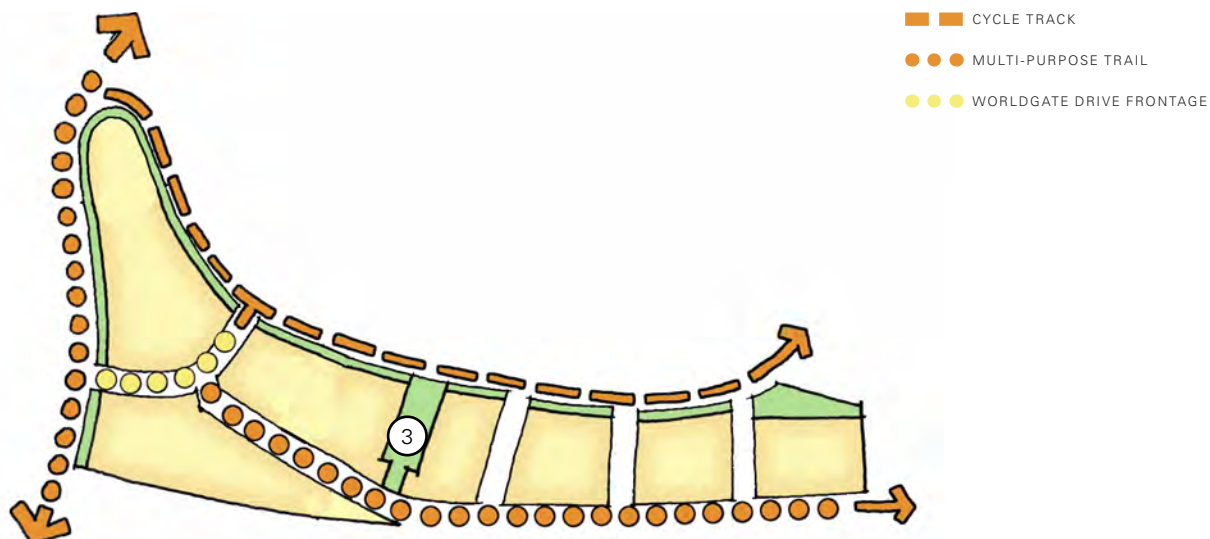



## VAN BUREN STREET

Part of the Metro station area fronts on Van Buren Street, between the Dulles Toll Road and Herndon Parkway. The appearance and function of this section of frontage are important to establish single-family residential neighborhoods to the north, and multi-family neighborhoods and existing business uses to the west. It also lies along a popular route for those destined for commuter parking south of the Dulles Toll Road or employment elsewhere. Although the frontage physically does not relate to the rest of the transit-oriented area on the east, it plays a crucial role in forming a first impression of the transit-oriented area and this frontage should not be regarded as the “back of the building” with lower quality facade design. The buildings along the Van Buren Street frontage should be designed with facades that are commensurate with typical front facades of buildings and should feature Metro area street lights and generous plantings. Storefronts may be located on Van Buren Street although they are preferred along the extension of Worldgate Drive and the Herndon Promenade. Space along Van Buren Street should be considered part of the pattern of for pedestrian circulation. Of primary importance is the provision of the regional Folly Lick Trail connection along Van Buren Street between the Washington and Old Dominion Railroad Regional Park and the regional trail system lying outside the town limits, south of the Dulles Toll Road.



SECTION C

ARCHITECTURAL GUIDELINES



# OVERVIEW

Like the Urban Design Principles in Section B, this section builds on the design principles articulated in the HTOC Plan to provide a more detailed set of guidelines for architecture. The architectural form of the transit-oriented area is composed of mid-rise buildings and towers.

Mid-rise and podium buildings are configured to define the public realm of the district and form the edges of streets, squares, and access drives. They consist of a wide variety of commercial uses, residential uses, and parking. These buildings, along with occasional towers, are envisioned along the frontage of Herndon Parkway and Van Buren Street. Parking structures should not exceed the height of the podium.

Towers may reach a total height of twenty stories from the ground level (including podium and parking decks) and are intended primarily for residential and office uses. Towers are envisioned along the Dulles Toll Road frontage and the frontage of the extension of Worldgate Drive. However, a uniform height along the Dulles Toll frontage is strongly discouraged.



*Existing historic buildings in downtown Herndon*



*Precedent mixed-use building*



*Podium-level buildings with a variety of towers will create an interesting and varied frontage along Dulles Toll Road*

## Building Forms

Each development area should be designed with a facade that has a harmonious treatment on all side of the perimeter to help define the public space of the HTOC. Mid-rise and podium buildings should be articulated vertically to resemble an ensemble of smaller buildings and horizontally into a base, middle, and top. These buildings will be the architectural frames for retail and entertainment uses on the ground floor.

Office and residential uses may occupy the upper floors. Parking garage frontages are discouraged on certain streets. Ideally, parking is provided behind a liner of active uses or in a stand-alone garage within the envelope of the podium. Parking deck entrances should be avoided on Herndon Parkway and the extension of Worldgate Drive.

Towers present a remarkable opportunity to create a strong visual identity for Herndon. Towers are encouraged to be as tall as 275 feet along the Dulles Toll Road and up to 225 feet along Herndon Parkway. The developer is allowed great flexibility in the configuration and location of towers to meet market demand. Upper floors should be recessed increasingly greater distances from the street or sides of the lot. They should be configured to fit the needs of tenants. Towers should be located to minimize adverse impacts on public spaces, and their solar orientation should be carefully considered.



*Podium Building*



*Tower Building*



*Podium Building with a Tower rising beyond*



*Podium Building*

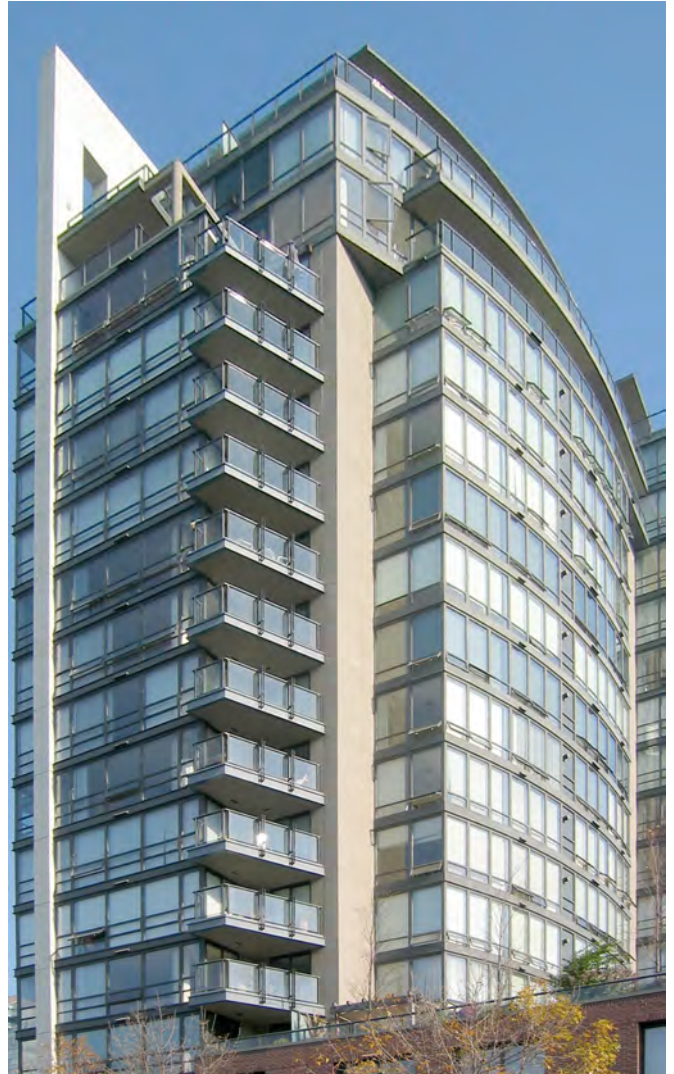

*Tower Building*

# Massing and Skyline

The intent in the Metro station area is to have an interesting skyline with a variety of forms and heights. The profile of the district from the Dulles Toll Road should draw interest and establish the Herndon Transit-Oriented Core as a unique place in the region. One way to achieve this is for buildings to have interesting articulation along the roof line, and to avoid a monotonous profile when viewing the area at build out. Creative building lighting can also add interest to the appearance of the building's exterior.

New buildings in the HTOC may accommodate a wide range of uses that will benefit from a flexible approach to development. Some may be built for rental and home ownership residential uses, others for a wide range of commercial uses. Developers should be allowed to respond to market demands within a framework that results in a creative and vibrant new district. In general, basic building massing should be modified using principles of composition to articulate large building masses to appear as a collection of smaller parts. This approach scales new development to the traditional form of the Town, which was built in smaller increments. The diagram series to the right illustrates a preferred approach for mitigating building mass of new development in the HTOC.

## MITIGATING BUILDING MASS

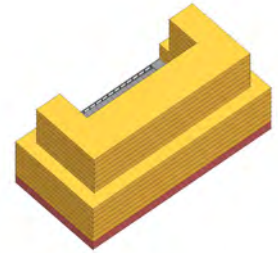

1 - Establish general building envelope

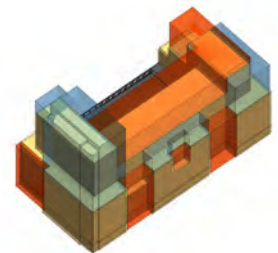

2 - Articulate the massing and sculpt the building by adding and subtracting volume

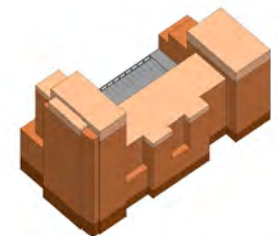

3 - Define a base, middle, and top



4 - Articulate the building by establishing bays, applying building elements, changing materials, etc.



## MID-RISE AND PODIUM BUILDINGS

The first six floors of development clearly define the urban spaces of the district and may accommodate retail, restaurants, entertainment uses, lobbies, and parking as well as residential and office uses. Mid-rise and podium buildings are articulated as continuous street-oriented architecture designed to a pedestrian-scale, sometimes with active ground floor uses.

## TOWERS

Buildings above six floors should be arranged into towers, designed to meet the requirements of the marketplace. One developer may wish to build large floor plate offices while another may choose to build smaller floor plate residential towers. Towers should transition in height from a possible 275 feet along the Dulles Toll Road to a possible 225 feet along Herndon Parkway. The Town encourages towers of varying heights designed with interesting tops, such as articulated parapets, sloped roofs, and crowns that distinguish the buildings from conventional flat-topped architecture along the Dulles Toll Road.

### MID-RISE AND PODIUM BUILDINGS

Mid-rise and podium buildings can house residential, office, or commercial uses either in a single or mixed-use format. These buildings should have consistent massing while incorporating human-scale elements (such as ground floor commercial storefronts) that respond to the objectives of the HTOC.

Mid-rise buildings and podiums may be intricate buildings that combine many uses and circulation patterns. A logical pattern of development will be to locate parking garages in the middle of the block wrapped with active uses that front public streets and plazas. Developers should consider interior alleys, courtyards, and passages to bring light into the middle of development sites. These internal passages will provide natural divisions for phasing development, and will also provide the necessary circulation for service and parking access. They can have the added benefit of breaking the size of monolithic developments into smaller increments. The internal passages should be designed with the pedestrian and public in mind so that the district as a whole will be enriched with this secondary circulation network.

The most successful development in the HTOC will not be perceived as a single massive building but rather as a collection of street-oriented buildings forming an urban block. This can be accomplished with variable building heights, facade compositions, and materials.

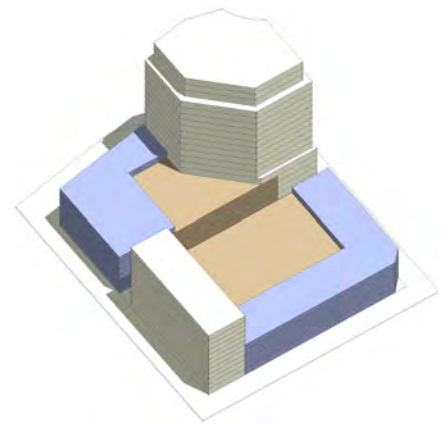

- ESSENTIAL CHARACTERISTICS**
- » Preferred minimum height = 3 stories
  - » Vertical expression from 60 to 120 feet in width (to simulate smaller buildings forming a street wall)
  - » Preferred commercial ground floor height = minimum, 18 feet
  - » Recognizable horizontal divisions into a base, middle, and top using a variety of architectural elements is desirable
  - » Regular patterns, whether symmetrical or asymmetrical, of openings and accents
  - » Bay windows or grouped windows as accents
  - » Storefronts and active lobbies along frontages
  - » Residential ground floor uses should be 2 feet above exterior grade level and separated from sidewalks with planting areas

### ELEMENTS OF MID-RISE AND PODIUM BUILDINGS

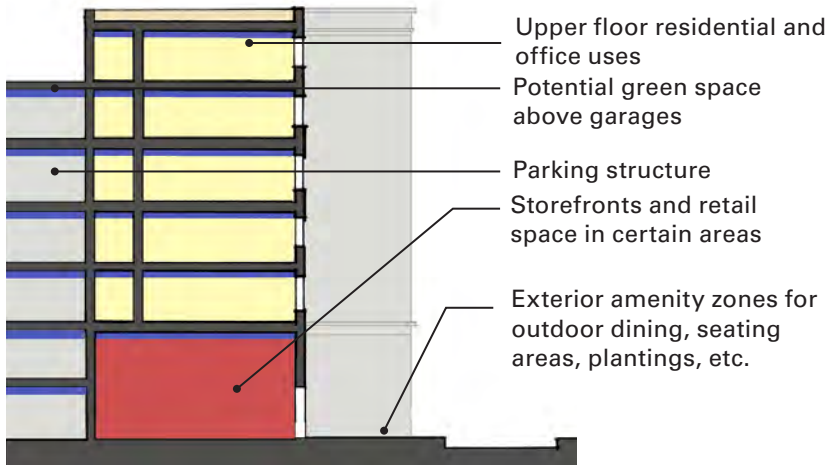

## RECOMMENDED COMPOSITION



### BASE, MIDDLE, TOP

- » Horizontal elements delineate a base, middle, and top
- » Cornice, eave, and parapet treatment and tower details create a more compelling skyline
- » Articulated bases address the street at a comfortable scale for pedestrians



### BAYS AND EMPHASIS

- » Identify a pattern of bays to organize the facade
- » Bay spacing is encouraged to vary between buildings and major massing elements to ensure variety

### WINDOWS AND DOORS

- » Openings may be symmetrical or asymmetrical across the facade
- » Arrangement and rhythm of openings should vary across the facade; paired and tripled groupings are common
- » Openings are vertical in proportion
- » Entrances are encouraged within prominent locations or within emphasized bays
- » Large openings may be divided into a series of panes
- » Window and door moldings provide additional opportunities for special detailing to help mitigate building mass
- » Curtain wall systems may be used but in limited areas



### TOWER BUILDINGS

Towers may be built up to a height of 275 feet and should have a lobby entrance from an exterior public space such as a street, access-drive, or promenade (not accessed solely from a parking garage). Likely, they will emerge from the podium but should have a clear address on the street or access drive and read as a separate building. Tower floor plates will vary, allowing efficient office or apartment floor plates. They should be elegantly proportioned to blend with adjacent buildings at the street level while rising dramatically to punctuate the skyline above.

Tower facades are articulated with a series of devices to emphasize verticality, particularly critical for large floor plate towers. Tower facades should have an articulated base, middle, and distinctive top.

#### TOWER DIAGRAM

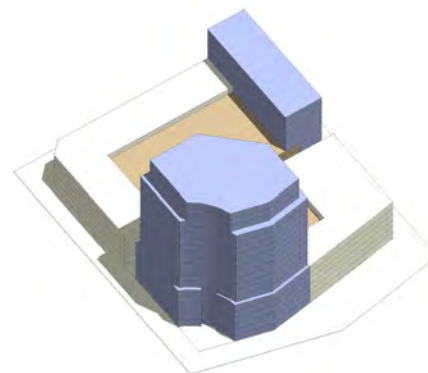
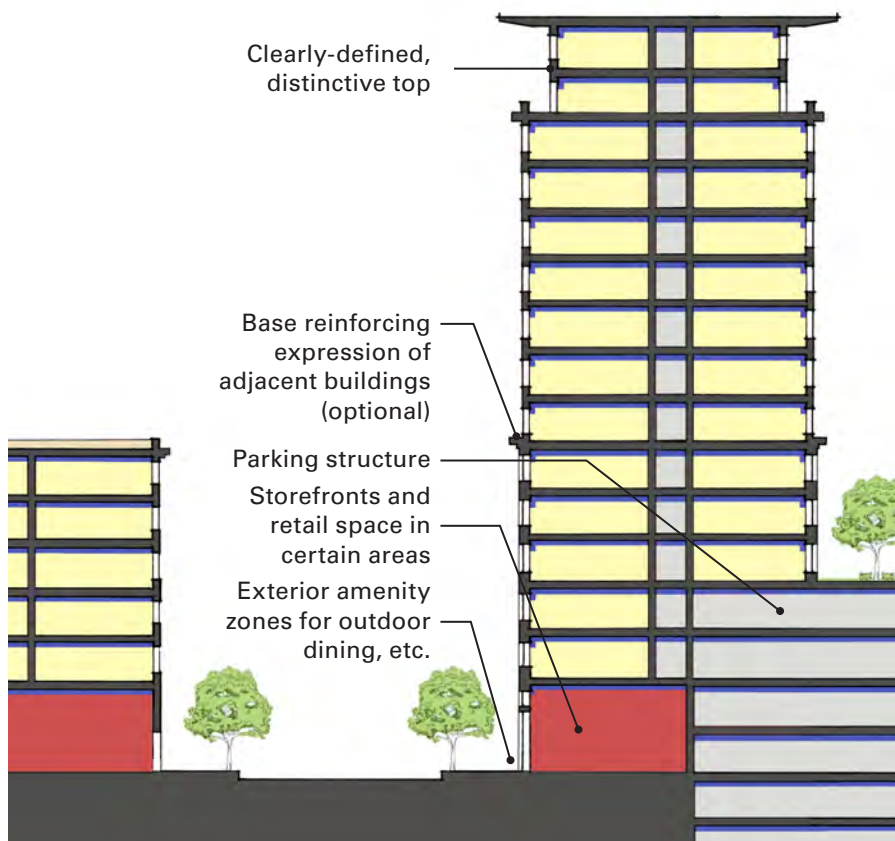

- ESSENTIAL CHARACTERISTICS**
- » 275 feet in height (225 feet along Herndon Parkway)
  - » Main body of the tower comes down to the street, access drive, or promenade level and has a clear independent entry
  - » A clearly defined top
  - » A clearly articulated base, relating to overall building height
  - » The base can reinforce the 6 story expression of adjacent buildings
  - » Variety of materials and window patterns



## RECOMMENDED COMPOSITION

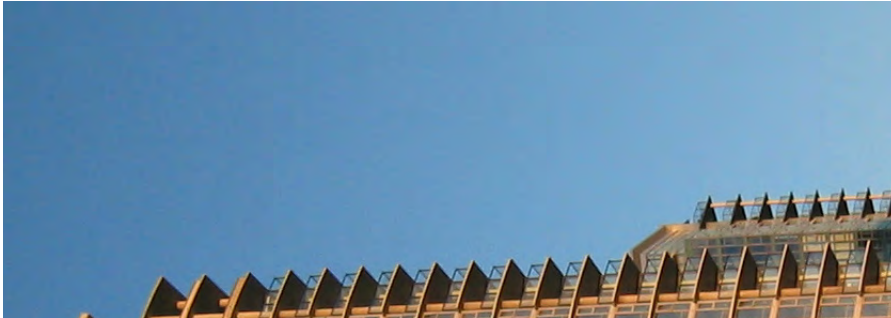

### BASE, MIDDLE, TOP

- » Horizontal elements or materials can delineate a base, middle, and top
- » Cornice, eave, and parapet treatment and tower details create a more compelling skyline
- » Articulated bases can address the street for a pedestrian scale



### BAYS AND EMPHASIS

- » Identify a pattern of bays
- » Primary and secondary bay rhythms are encouraged
- » Spacing is encouraged to vary between major massing elements to ensure variety

### WINDOWS AND DOORS

- » Symmetrical openings within each vertical shaft or bay can help distinguish the bay
- » Sizes and arrangement of openings are regular and aligned within each vertical shaft but can vary across the facade
- » Windows may be single or grouped; curtain wall systems are also appropriate
- » Windows can be vertically proportioned to emphasize tower height
- » Expansive openings can be divided into panes to reflect a residential scale; for office and commercial uses this is not necessary but encouraged
- » Entrances should be prominent and may be articulated as double-height openings



# Parking

Surface Parking Lots, Integral Parking, Podium Parking, and Free-Standing Parking Garages are possible configurations in the HTOC. The following pages describe each parking type and how it should be implemented. The design of parking lots and garages tends to be governed in the following ways:

### LOCATION ON THE SITE

Parking is most appropriate on a development site when it is sited with sensitivity to adjacent activities and features, including the adjacent right-of-way.

### SCREENING AND VISIBILITY

Some level of screening between the parking area and adjacent areas is usually provided. The Herndon Town Code governs the type of screening required of facilities depending on the location within the site.

Shade Trees and Parking area landscaping can be used around the structure as appropriate to intensify screening or create a landscape feature.

### INTERIM USE

Parking lots are not an anticipated feature within the HTOC but may be present prior to the final build out of a land bay at an interim stage.

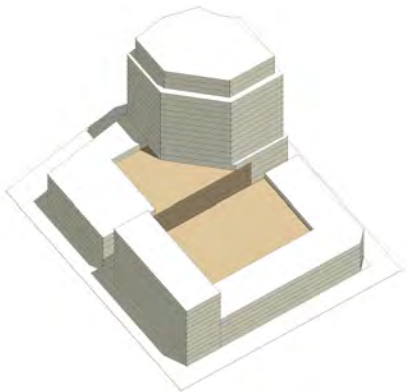

- ESSENTIAL CHARACTERISTICS**
- » Preferably located in center of development blocks
  - » Should be screened from primary pedestrian paths by buildings and lined by active uses
  - » When exposed to view, parking structures should have articulated facades
  - » Pedestrian access should be clearly visible and provide direct access to adjoining buildings and adjacent public spaces
  - » Vehicular entries should be located on access drives and internal service lanes
  - » Underground parking is encouraged throughout the HTOC

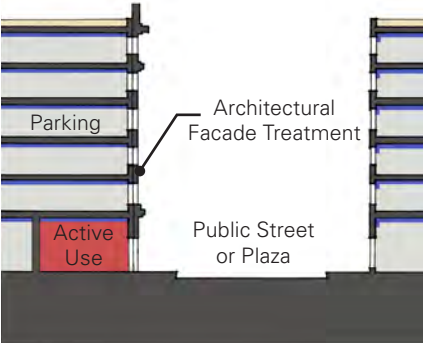

**ARCHITECTURAL FACADE**  
Parking garage buildings should be designed with facades of high architectural quality using materials to resemble adjacent buildings. Active ground floor commercial or residential uses are recommended instead of highly visible parking decks.

*Note: This typology is not encouraged along Herndon Parkway, the Promenade, and Worldgate Extension.*

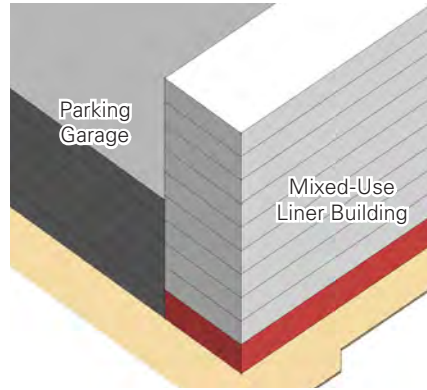
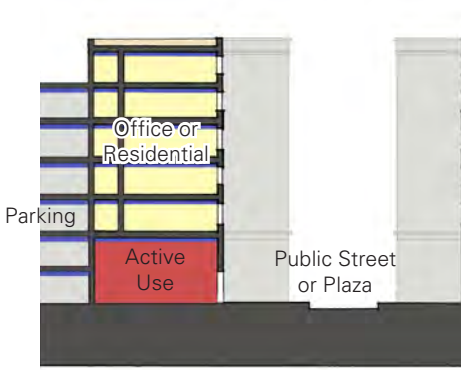

**ATTACHED LINER**

Garages may be concealed by occupied floors that are attached structures such as apartments with single-loaded corridors and shallow office floors. Top levels of garages may be concealed by green roofs, solar voltaic systems doubling as sun shades, and other sustainable techniques.

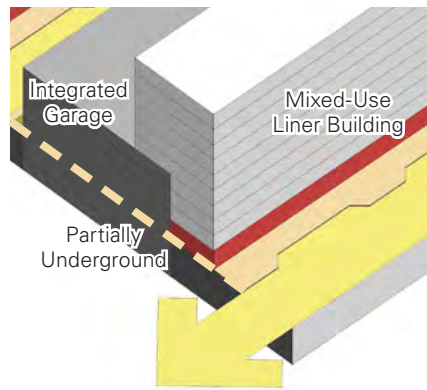
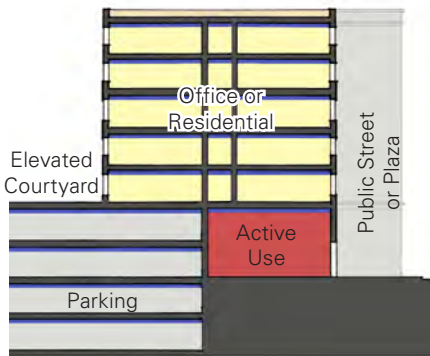

**PARTIAL UNDERGROUND**

Where possible, structured parking may be partially submerged allowing the possibility for elevated courtyards and buildings with double aspects (street and courtyard orientations).

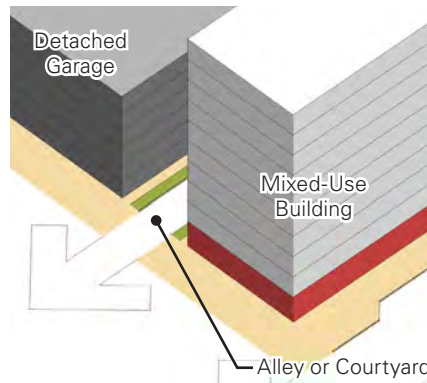

**DETACHED LINER & COURTYARD**

Buildings fronting streets may screen the view of free standing garages. The two buildings may be separated by an alley or courtyard.

# Phased Parking

Transit-oriented development is commonly phased for a variety of practical reasons. Providing suitable parking accommodations throughout the phased construction of the development can be challenging and is often described early in the planning process on the project’s concept plan. For example, over time, surface parking can be phased into structured parking or future buildings. The following information describes possible phasing strategies for parking and how parking may be incrementally developed into a denser site.



*Parking structures help developers build at higher densities and in phases. Throughout the HTOC, parking structures should be designed to resemble buildings.*

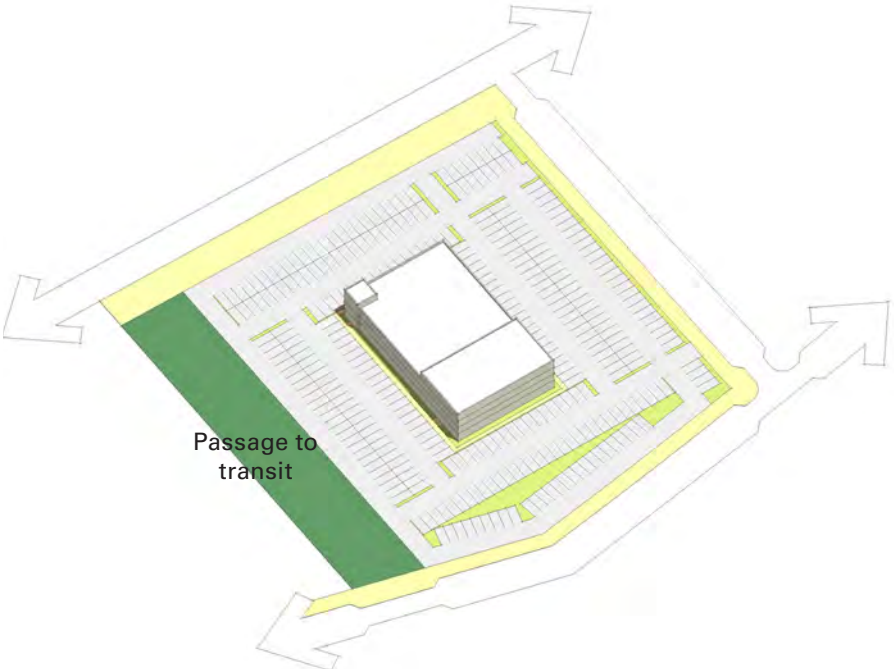

**EXISTING CONDITIONS**  
Existing development is typically an office building surrounded by surface parking. Access is from Herndon Parkway and the sites are not always connected. With the new transit station, the Town may permit development at higher densities. Property owners may be able to redevelop their parcels in phases, transitioning from surface parking to full development at much higher densities.



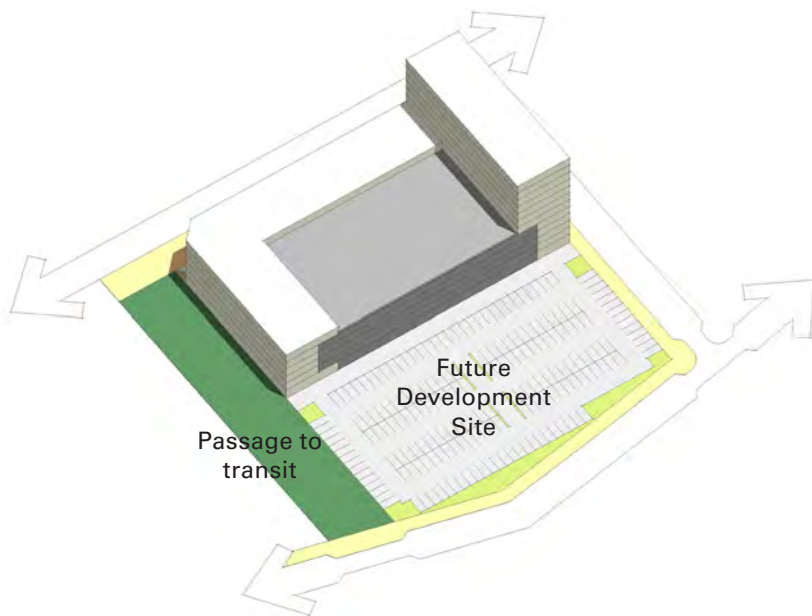

#### INTERIM PHASE

The existing building is removed and replaced with new development. Parking for the new building is a combination of a new structure and surface lots. The property owner has planned for new access to the sides and back of the parcel. This access is phased with future development and designed to enhance the pedestrian experience while providing appropriate vehicular access. Exposed parking structure facades should be screened or articulated with an appropriate architectural treatment.

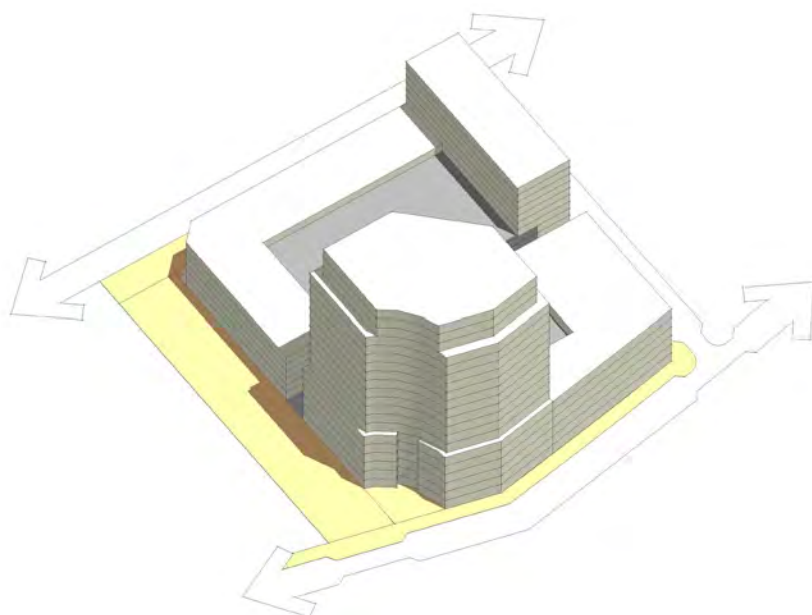

#### FULL BUILD-OUT

The block is fully developed and parking is located in large, internal mid-block garages.

## Special Architectural Elements

Special architectural elements are accessory features of the building that can increase square footage and/or enhance the usefulness of a building form. Special architectural elements also provide visual cues for how a building is used or lived in. They enrich the architecture and public spaces of the HTOC. This section provides a selection of possibilities though others may be proposed by architects and developers.

The plan of the HTOC suggests many opportunities for incorporating special elements into new development. Public streets and shared access drives create prominent corners that can be celebrated with special features on building facades. Several prominent vistas are created with the intersecting geometry of public streets, the Herndon Promenade, and private access drives. These vistas can create focal points for architectural elements.

The ground floor frontage along the extension of Worldgate Drive, Herndon Parkway in the vicinity of the Promenade, and the Promenade itself are appropriate locations for active ground floor uses, including commercial storefronts and residential lobbies. Shopping arcades and galleries can be considered to create additional public amenities in these areas. Awnings and signage can further enrich the ground floor shopping environment.

Residential areas can be visually distinguished with ADA accessible stoops and porches set back from the street with adjacent garden front yards. Balconies can be used to enrich apartment facades and connect residents with the outdoors. Gracious entrances to buildings can be created with forecourts, carved out of continuous street walls for entry gardens and covered entries. Porte cocheres can create distinctive architectural features for hotels and apartment buildings.

### STOREFRONT

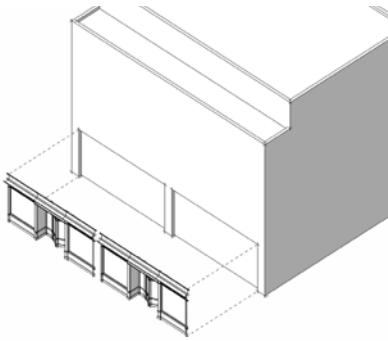

Storefronts are appropriate along portions of Herndon Parkway, the extension of Worldgate Drive, and the Promenade. Please refer to the Storefronts and Exterior Amenity Zones section of these guidelines.

### ARCADE

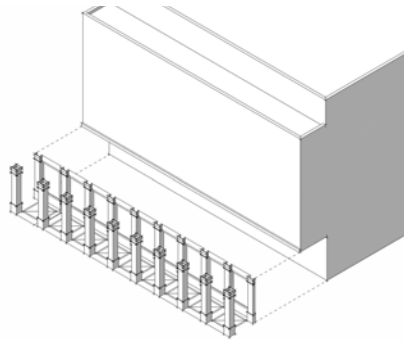

Arcades are welcome amenities, especially where they provide sheltered passage for pedestrians going to transit. They should also be considered for building entrances and outdoor dining. Arcades should be designed to ensure adequate daytime and nighttime lighting and be lined by active lobbies and storefronts.

### GALLERY

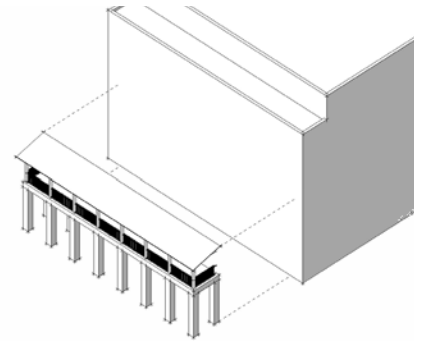

Galleries are permitted and are particularly desirable for two-story restaurants where outdoor dining is desired on two levels. They can add a distinctive character to commercial frontages.



AWNING

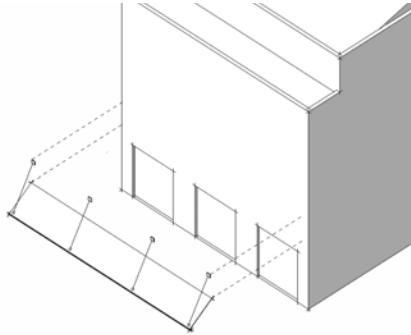

Awnings come in many forms and materials, from temporary fabric awnings to permanent metal, glass, and composite materials. Awnings are welcome additions to ground levels and provide shelter from inclement weather for building entries and storefronts.

PORTE COCHERE

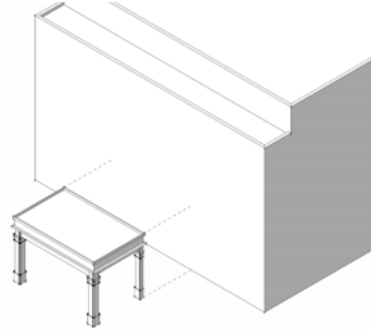

Porte cocheres are desirable for hotel entrances as well as some multi-family structures where the drop-off function can provide weather protection. Porte cocheres should not intrude into the street spaces and must be coordinated carefully with bicycle and pedestrian pathways. Porte cocheres should be entirely contained within the buildable area of parcels.

FORECOURT/ LOBBY ENTRANCE

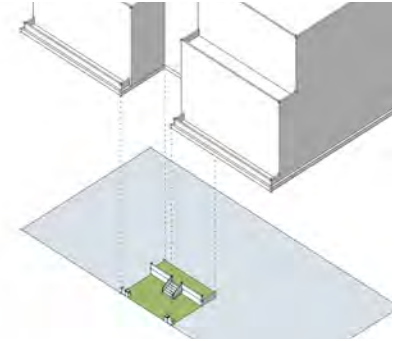

Forecourts are small public spaces that are part of the entry sequence of buildings. They provide attractive settings for building entrances and lobbies and create gathering areas outside of the pedestrian traffic flows of the sidewalks. They present great opportunities for landscaping.

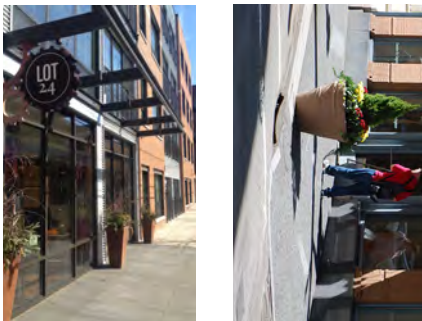

## STOOP AND ENTRY PORCH

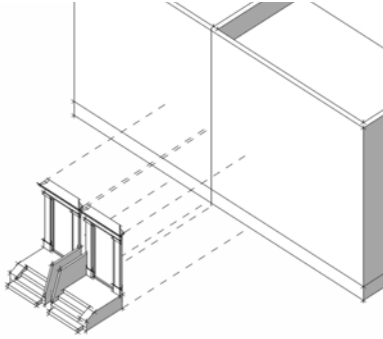

Stoops provide street entrances to attached single-family residences. The first floor of residences should be a minimum of 2 feet above grade. Stoops provide the transition from the street to the front door and may be covered with porch roofs or awnings and flanked with landscaped yards. Attached single-family units with private entries can be embedded in the bases of larger buildings.



## BALCONY

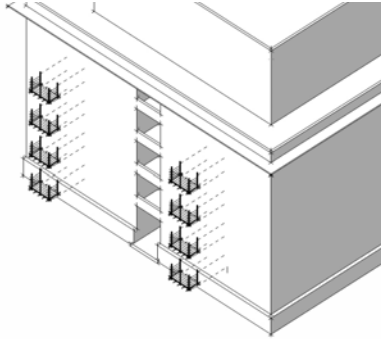

Balconies are encouraged, particularly for residential buildings. They provide outdoor living spaces for apartments and condominiums and enrich the composition of buildings. Balconies may either project from the facade or be recessed into the building mass or a combination of both.

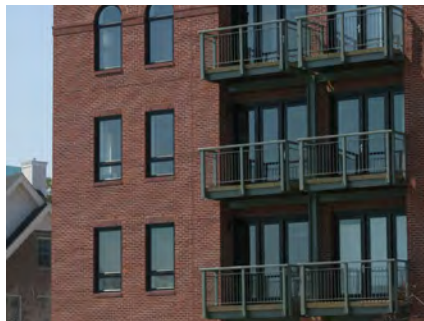

# Storefronts

For mixed-use buildings in the HTOC, the design of storefronts and the relationship between interior building spaces and exterior pedestrian spaces is especially important. The design of storefronts is critical to the success of the pedestrian realm and will impact the sense of security and safety in the neighborhood. The following are a series of elements that should be considered:

### STOREFRONT COMPOSITION

- » Ground-floor retail spaces having a minimum height of 18 feet from floor to finished ceiling.
- » Storefront design utilizing the full height of the ground-floor facade frontage.

### OPENINGS AND TRANSPARENCY

- » Glazing should constitute a minimum of 60% of the ground-floor retail facades.
- » Shop windows should provide views into the shop as well as its displays.
- » Exterior window signage is highly preferred over interior window signage.
- » Opaque tinting, window shade, and blinds that block visual interaction between the street and the interior are discouraged.

### AWNINGS

- » Awnings are encouraged and may provide additional signage space by incorporating names and logos.
- » Plastic, over-scaled, and fluorescent back-lit or internally-lit signs and awnings are discouraged.

### STOREFRONTS

- » Storefronts should be designed using traditionally framed elements of retail design as well as innovative new components that emulate the composition of traditional retail design. Characteristic elements include large transparent display windows with kick plates below and clerestory windows above, recessed front entries, and exterior awnings and signs.

**UNDESIRABLE STOREFRONTS**

- » Cluttered shop windows with reduced or impeded visibility between the interior and exterior
- » Fluorescent lighting
- » Backlit signs and awnings
- » Solid security gates
- » Boarded up storefront window areas
- » Reflective glazing
- » Inaccessible entries
- » Paint colors inconsistent with the area



- » Multiple storefronts within the same building should be visually compatible in terms of scale, alignment, and their relationship to the building as a whole, yet distinguished between various shops using storefront design, color, signage and other elements. The coherence of the building design should be able to accommodate the diversity of character and individuality amongst various shops in one building.
- » Storefronts should maintain a typical rhythm wherever possible, such as 10 to 20 or 15 to 30 feet wide at the ground level, each with its own entry. Even if one tenant occupies a wider area, the visual rhythm should be maintained.
- » Storefront entrances should be clearly distinguished from entrances serving floors above.
- » Kick plates, windows, transoms, clerestories, signage bands, upper floor windows, and cornices should align where possible among adjacent bays but should allow for a level of vertical, horizontal, and three-dimensional variations at the lower level to help create a varied and organic quality for the storefronts.
- » Windows should have 60% transparency into the interior.
- » Individual storefronts should be distinguished by interesting design features at the ground level, such as lighting, medallions, belt courses, plinths for columns, piers or pilasters, projecting sills, tile work, stone or concrete masonry, pedestrian-scaled signs, planter boxes, and specialty bay windows.
- » Within the compositional framework above, storefronts may be composed of various kinds of operational doors and windows that will encourage the opening-up of interior spaces onto sidewalks and terraces. Examples include French doors, modified garage doors, sliding doors, walk-through double- and triple-hung windows, and others that can support the opening-up of interior spaces to the outside where appropriate.
- » Shadow boxes less than 36 inches deep are discouraged in order to encourage visible, active uses in the storefront.
- » Lobby and tenant lighting should be visible from the outside at night.



## STOREFRONT MATERIALS

- » Brick, stone, cast stone, ceramic tile, hard coat stucco, wood, wood substitute (smooth finish, cementitious planks and panels or cellular PVC) or pre-finished heavy gauge metal panels are preferred. Entrance doors generally should be clear glass in wood or metal frames.
- » Storefront windows typically consist of large, transparent plate glass set in wood, clad wood, or metal frames. Display windows should incorporate high transparency glass with high visibility transmittance values (37% or greater) and low daylight reflectance (15% or less). Colored, visibly tinted, or mirrored glazing is not recommended for storefronts.
- » Storefront windows may be or give the appearance of being divided into small, multiple lights. Transoms may be divided into multiple lights by muntins applied to the exterior, giving the appearance of true divided lights or through the use of small glass blocks.

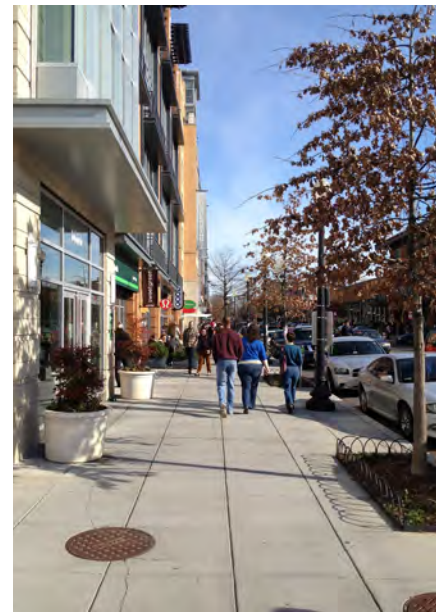



# Exterior Amenity Zones

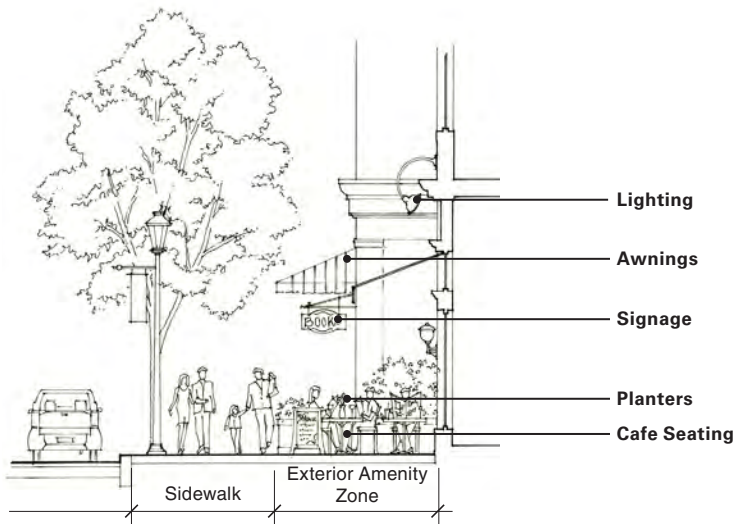

*(Above) Active sidewalk experiences that includes outdoor dining, various types of storefronts, and interesting entry element*

- » Retail, restaurant, and other food and beverage operators are encouraged to provide and operate exterior amenity zones in front of their storefronts in a manner that will create a seamless connection from their interior operation to exterior spaces.
- » Storefront designs that reinforce the connection between inside and outside are encouraged. With carefully-selected materials, storefront designs can use operational doors and windows that allow for direct connection and movement between the sidewalk and restaurant and shop interiors.
- » Restaurants and shops are encouraged to maximize the use of exterior space as an extension of interior activity.
- » The use of outdoor plantings, planting boxes, and flower boxes is recommended in exterior amenity zones.
- » Awnings, canvas umbrellas, decorative lighting, and heat lamps can be used to extend the seasonal use of sidewalk areas.

# Materials

## CLADDING SYSTEMS

Buildings are designed using a range of wall cladding systems to organize and express the massing of mid-rise buildings, podiums, and towers as a series of smaller components. This approach allows the observer to see a development with a seemingly large mass as a series of smaller buildings assembled to create the feel of an urban block more oriented towards and comfortable for sidewalk users. The use of plane changes, different materials, and color are tools available to the architect to serve this purpose. The choice of wall systems is influenced by views and solar orientation. Buildings may use a mix of cladding systems.

## MASONRY CLADDING SYSTEMS

Masonry wall systems are suggested, particularly at the podium levels. A range of masonry materials will add color and solidity to buildings in the district. Architects are encouraged to consider brick, stone, and precast concrete at the base of buildings where they receive the most weathering.

## GLASS CURTAIN WALLS

The best glass curtain wall systems use non-reflective glazing or nearly transparent solar coatings for window areas. The addition of spandrel glass and metal panels can give curtain walls a richness of depth and color. Since these systems are often used to create dramatic glazed corners and window bays, they are to be avoided in use across facades where they may create a monotonous uniformity.

## FLOOR-TO-CEILING GLAZING SYSTEMS

These systems are framed between concrete floor slabs at balconies and in walls where articulation of the doors is desired. The structure of the building is exposed and used to create interesting visual effects in combination with continuous curtain walls and masonry cladding systems.

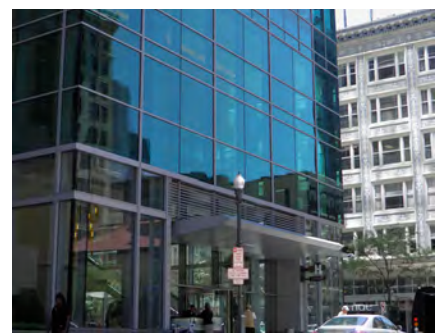
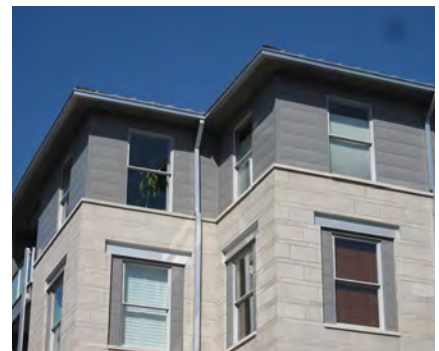
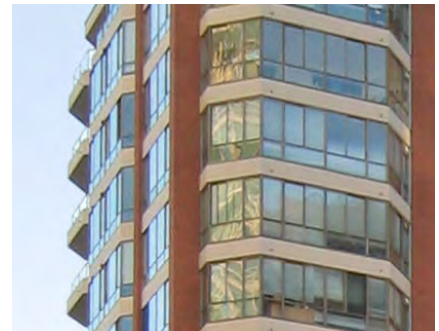

## SUGGESTED MATERIALS

(OTHER MATERIALS MAY ALSO BE APPROPRIATE)

### CLADDING

Brick, stone, cast stone, precast concrete, glass fiber reinforced cement, metal and composite panel systems, and aluminum and glass curtain walls. Masonry wall systems are suggested, particularly at the podium levels. (See page 52 for storefront materials). Exterior insulation and finishing system (EIFS) generally is discouraged.

### ROOFING

Flat roofing systems with stone or cast stone or precast parapets may be used for towers although interesting tops, such as articulated parapets, sloped roofs, and crowns should be employed to distinguish the buildings from conventional flat-topped architecture along the Dulles Toll Road. Standing seam metal or other decorative roofing is recommended for exposed roofs on lower floors. Vegetated roofs are preferred wherever possible.

### WINDOW WALLS

Aluminum framing systems with clear or “E” coated glazing, spandrel glass and metal panels may be used. Glazing systems that seek uniformity across facades are not recommended.

### WINDOWS

Aluminum window systems, coated steel window systems, clear or “E” coated glazing, spandrel glass and metal panels

### TRIM

- » Overall building: Stone, cast stone, and stone string courses, lintels, and sills
- » Storefronts or other entrance areas: Durable weather resistant and impact resistant materials

### COLUMNS

- » Overall building: Brick, stone, cast stone, precast concrete, glass fiber reinforced cement, aluminum, or steel. Wood columns may be appropriate for residential buildings.
- » Storefronts or other entrance areas: Durable weather resistant and impact resistant materials

### BALCONIES

Concrete or steel with aluminum, steel, or glass railing systems

### SOFFITS

Concrete, stucco, fiber cement, wood, or prefinished aluminum. Exterior insulation and finishing system (EIFS) generally is discouraged.

### CANOPIES

Metal, glass, wood, or canvas awnings

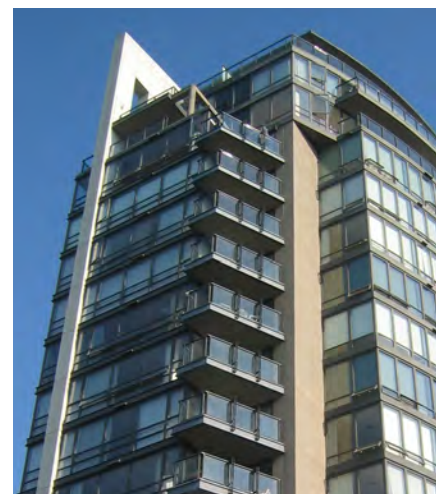
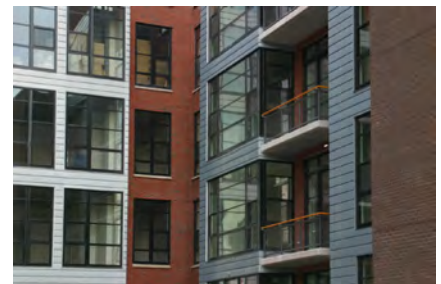
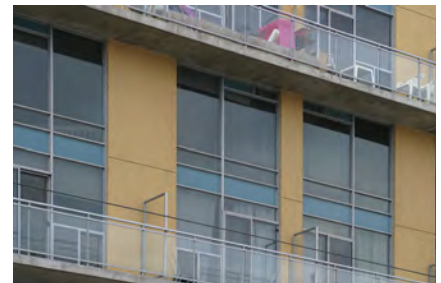
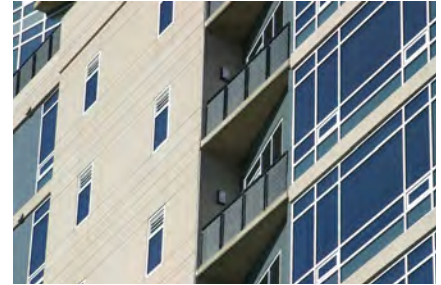

## Green Roofs

In the site redevelopment, owners are encouraged to consider incorporating green roofs into building design. Numerous benefits can result from the adoption of green roof technologies including the recovery of green space, moderation of the urban heat island effect, improved storm water management, water and air purification, and a reduction in energy consumption. A major benefit of green roofs is their ability to absorb storm water and release it slowly over a period of several hours. Green roof systems have been shown to retain 60–100% of the storm water they receive. In addition, green roofs can have a longer life-span than standard roofs because they are protected from ultraviolet radiation and the extreme fluctuations in temperature that cause roof membranes to deteriorate.

While green roofs provide additional usable open space for city dwellers, if planted with appropriate material, they also provide habitats for a variety of bird, butterfly, and insect species. Green roofs are encouraged on exposed areas including parking structures, commercial and residential units, as well as bus stop shelters and small pavilions.

### ILLUSTRATIVE LIST OF GREEN ROOF PLANTS

- |                                  |                     |
|----------------------------------|---------------------|
| » <i>Aquilegia canadensis</i>    | Red Columbine       |
| » <i>Asclepias tuberosa</i>      | Butterfly Milkweed  |
| » <i>Bouteloua curtipendula</i>  | Sideoats Grama      |
| » <i>Carex radiata</i>           | Fox Sedge           |
| » <i>Coreopsis lanceolata</i>    | Lanceleaf Coreopsis |
| » <i>Elymus elymoides</i>        | Bottlebrush Grass   |
| » <i>Rudbeckia hirta</i>         | Black-eyed Susan    |
| » <i>Schizachyrium scoparium</i> | Little Bluestem     |
| » <i>Sempervivum</i> species     | Hens and Chicks     |
| » <i>Sporobolus heterolepis</i>  | Prairie Dropseed    |
| » <i>Talinum calycinum</i>       | Fameflower          |
| » <i>Tradescantia ohiensis</i>   | Spiderwort          |
| » <i>Viola pedata</i>            | Bird's-foot Violet  |



*Precedent image showing a class meeting on a green roof. Green roofs provide additional usable outdoor space within the urban fabric.*



*Detail photos showing extensive plantings on the left versus intensive plantings requiring more soil depth on the right.*



*Precedent image showing a green roof park with a promenade, native plantings, and seating.*



*Native perennial planting on the Allegheny County Office building's green roof provide visitors with an unexpected garden.*

SECTION D

LANDSCAPING GUIDELINES

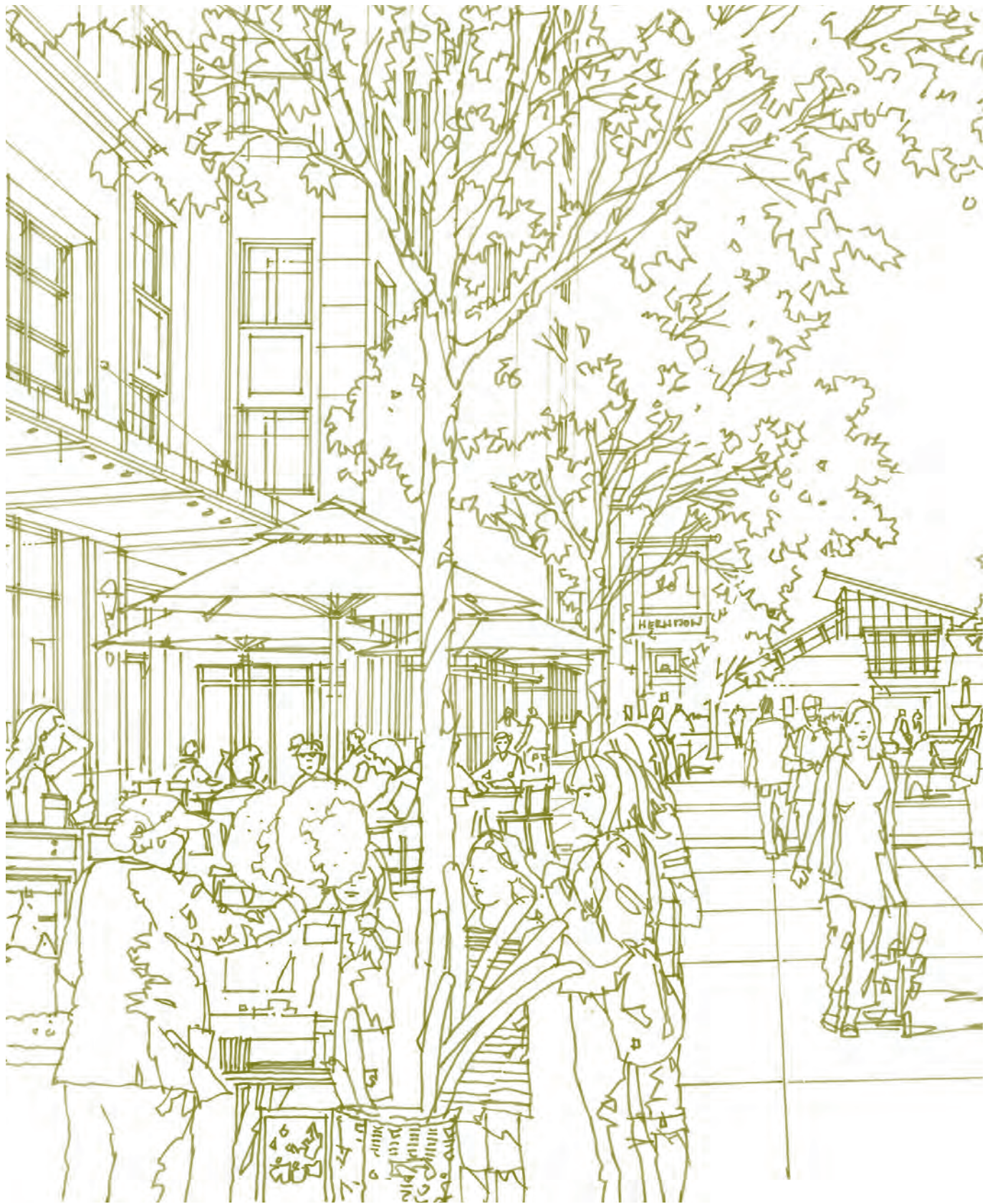

TO BE ADDED AT THE TOWN'S REQUEST AT A LATER DATE





SECTION E

SUSTAINABILITY

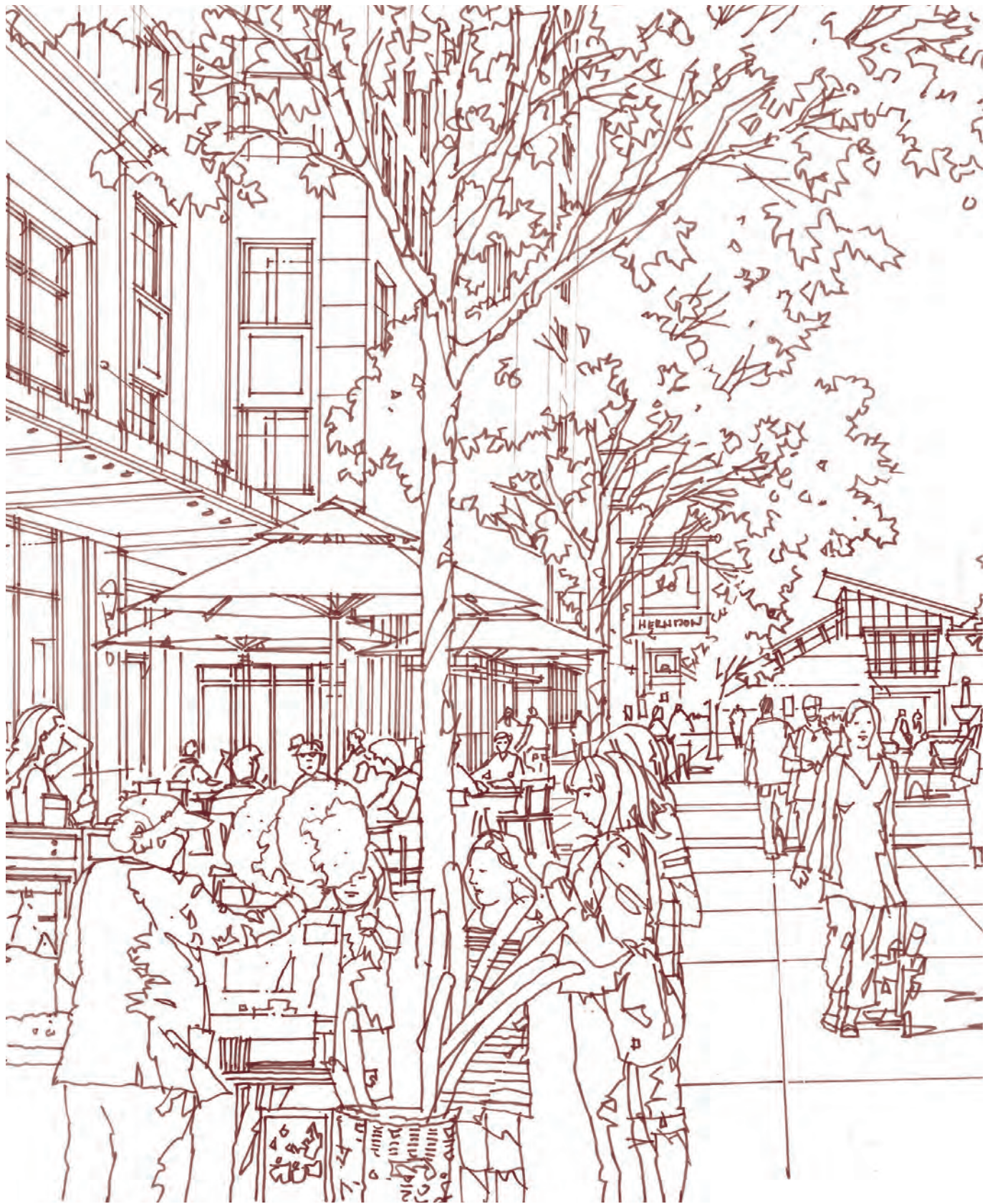

# OVERVIEW

This section provides guidance and suggestions regarding sustainability measures for buildings and general considerations for the HTOC as a whole. Applying sustainable practices can minimize impact on ecosystems and water resources, promote smarter water use, promote better building energy performance, reduce waste, and improve the quality of the indoor environment. Building developers may use a building design rating system at the beginning of the redevelopment process as a design tool. The nature of the HTOC gives developers a big head start in creating a sustainable development because the area will already meet some criteria by being within an existing urbanized area, being connected by transit to the region, being served by existing street and utility systems, and being connected to the community with pedestrian and cycle trails.

Available strategies for new building design include durable buildings with flexible floor plates that can accommodate a variety of uses over time, sophisticated building envelope systems including green roofs that reduce heating, cooling, and lighting requirements, and water and waste management strategies that reduce water usage and maximize recycling. Each new building provides the opportunity to further advance sustainability through environmentally conscious building design.

The guidelines below contain some of the sustainable practices suitable for Herndon's new transit area.



*The HTOC will be connected to the region with pedestrian and cycle trails that provide multiple modes of access, instead of relying solely on the automobile.*

## Green Roofs

(See also Section C, Architectural Guidelines)

Green roofs serve a double purpose of reducing heat island effects and helping to manage storm water runoff. Parking garages and buildings are encouraged to have green roofs that can also accommodate amenities such as pools and outdoor recreation areas. This approach adds value to developments by transforming roofs into internal courtyard parks and active recreational space.



## Building Orientation

(See also Section C, Architectural Guidelines)

If the parcels in the HTOC are developed to the density discussed in the adopted Comprehensive Plan, some towers could be built and located within proximity to each other. The location and orientation of towers should consider views, solar heat gain, shadows cast on public and private spaces and wind tunnel effects. Distances between buildings should be designed to correlate with building height to ensure spacing sufficient to allow light into each public space of the HTOC. Towers should consider orientations that maximize east/west wall lengths for solar considerations.

# Natural Light and Ventilation

Windows may be operable and spaced according to the patterns presented in the wall systems. Transparent openings should be sufficiently tall and appropriately located within the room for residents to view out. Commercial spaces may incorporate operable openings as well as awnings or solar shades for natural control of daylight and shading.

# Local and Recycled Materials

The use of local and regional materials, as well as recycled materials, is encouraged to reduce energy consumption (by the transit of materials from far away) in the construction of buildings in the HTOC. Materials manufactured locally also will benefit from a reduced cost of transportation. Recycled materials reduce consumption of non-renewable resources.

## Storm Water Systems

The responsible management of water is a critical component of any sustainable development and is an important issue for the Town. The aggressive management of storm water runoff should be a major priority for this redevelopment site, and is required by Virginia's Chesapeake Bay Preservation Act. Some Low Impact Development (LID) techniques are already employed in Herndon and include rain gardens, bio retention filters, rain barrels, and other modest measures to control storm water on site. These techniques can be applied in the HTOC and may help exceed minimum requirements.

Additional storm water practices that can be applied in the HTOC include:

- » Implement an array of localized or centralized techniques, such as green roofs, porous pavement, amended soils, infiltration practices, and rainwater harvesting to retain on-site and infiltrate, evapotranspire, and reuse rainfall.
- » Public streetscapes often can incorporate storm water planters and porous parking strips with sub-surface recharge beds, to treat and retain the maximum volume of storm water feasible.
- » Other storm water management techniques can include sub-surface infiltration and/or rainwater harvesting. Harvested rainwater can be reused for irrigation or ornamental water features or other non-potable water uses, such as toilet flushing or cooling tower makeup.
- » Tree box filters are encouraged in the HTOC as an additional means of managing storm water quality and quantity (please see compliance standards in Section 6-1309 Tree Box Filters of the Fairfax County Public Facilities Manual).



*Above ground retention*



*Below ground retention*



ON-SITE APPROACH



*Above ground retention on a roof garden*



*Stormwater wetlands in bloom. A variety of textures and colors provide visual interest for the pedestrian realm while allowing rainwater to slowly infiltrate.*

PUBLIC STREETScape APPROACH

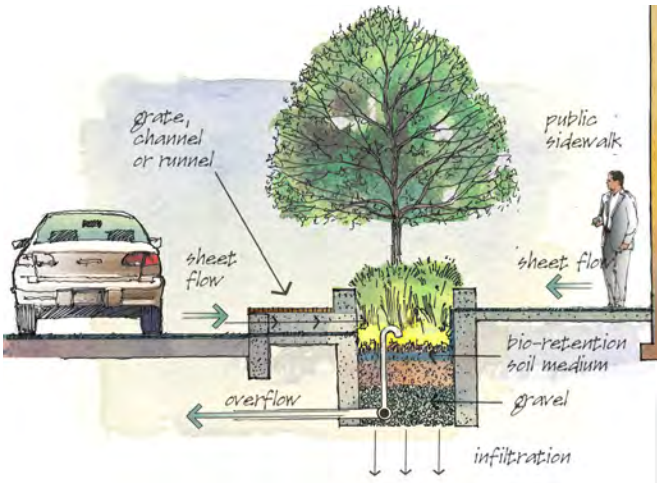

*Section through a stormwater planter*

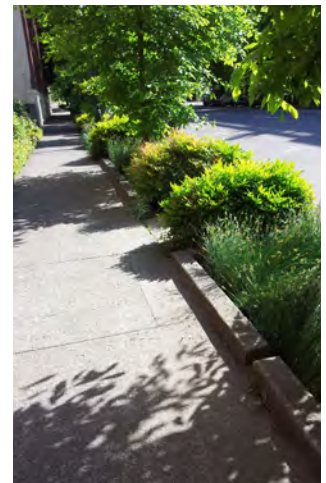

*Public streets using stormwater planters to capture rainwater*

OTHER APPROACHES



*(Far left) Sub-surface stormwater retention occurs at this recessed lawn (Left) Rain chains collect water for use as harvested building grey water*

SECTION F

SAFETY AND SECURITY



# OVERVIEW

A critical consideration for any future development is the provision for a secure and healthy environment. There are certain design measures that enhance the security of a neighborhood and reduce the risk for criminal activity. It is therefore recommended that owners consider applying Crime Prevention through Environmental Design (CPTED) principles as new projects are brought forth. CPTED involves designing physical environments to positively influence behavior. Users of a place feel safe and potential criminals sense risk.

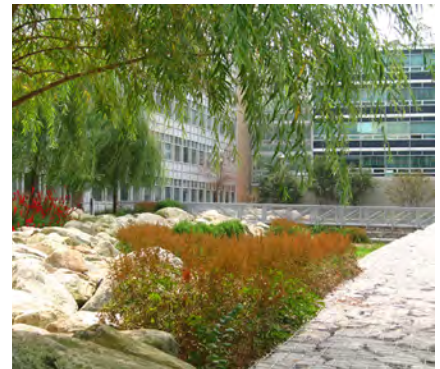

# Safety and Security: CPTED Principles

## NATURAL SURVEILLANCE

“Natural Surveillance” means keeping people and their activities easily observable. Design strategies include:

- » Doors and windows that face streets and public areas;
- » Balconies and porches;
- » Pedestrian-friendly sidewalks and streets;
- » Lighting:
  - › lighting of travel ways;
  - › exterior and interior lighting of ground floor uses even when closed;
  - › during interim development prior to build out, avoidance of dark or unlit areas and areas with blind spots or low-visibility;
  - › the use of sodium vapor and high pressure sodium vapor lights is not permitted; and
  - › note that paths and trails should also be lighted in addition to travel ways.
- » Well maintenance.

## TERRITORIAL REINFORCEMENT

Developing a sense of territorial control and ownership among users of a place helps increase safety. This can be accomplished by clearly defining public and private spaces with landscape plantings, lighting, special pavement patterns, gateway treatments and fences, as appropriate.

## NATURAL ACCESS CONTROL

Site and building design physically guide the circulation, entry and exit of people. The location of entrances, fences, landscaping, and lighting can aid site users while denying access to crime targets, and generating perception of risk in potential offenders. Design strategies include clearly indicating public ways and providing structural elements that discourage access to private areas.

## MAINTENANCE

Sites that appear well maintained tend to be more inviting to site users. A groomed landscape, proper lighting, and control of litter help site users feel safer. Potential offenders, sensing greater risk, may be less likely to intrude on such sites.

SECTION G

INTERIM CONDITIONS AND PHASING OF DEVELOPMENT



# OVERVIEW

Some sites in the Herndon Transit-Oriented Core will be developed in the near future, while others may take years to redevelop. As such, interim conditions may last anywhere from two to twenty years or longer. It is important that even the interim conditions result in enhanced connectivity, functionality, and a pleasant appearance.

Interim conditions must be considered early and throughout the design of a project and should include considerations such as temporary designs for the pedestrian realm, streetscapes, and connectivity to Metro, treatment of partially constructed building podiums, storm water facilities, urban parks, and improvements to the appearance and environmental impact of existing, interim parking lots. Consider installing street trees and trees along private access drives early in development phases to provide maximum time for trees to reach their expected canopy size. Construction sites are another part of the landscape that, although less permanent than other interim conditions, will affect the appearance and quality of the pedestrian realm for many years to come. Their creative and safe integration into the streetscape will help minimize their impact on the pedestrian and bicyclist experience.



# Interim Connectivity and Streetscape

One of the most important objectives is to ensure that pedestrians and bicyclists have a safe and pleasant route to Metro from their homes, places of employment, and to and from other activities. All redevelopment proposals should study existing and proposed pedestrian/bicycle connectivity within each potential phasing sequence to determine the need for interim design solutions that will provide connectivity. While it is understood that exact phasing sequences will be dependent on market conditions, a plan indicating how interim conditions will be addressed is essential for all redevelopment proposals.

Interim conditions should attempt to create a pedestrian/bicycle and vehicular network that closely approximates the expected final condition. Mobility connections, along with streetscape segments, may be necessary during different development phases depending on a variety of factors, including accessibility and pedestrian and traffic volumes. It may also be more cost effective for construction of full segments of streetscape and private access drives in earlier development phases as it will not require remobilizing construction equipment later on. A helpful approach to these various considerations for any redevelopment proposal could include:

- » Determine which pedestrian- or bicycle-oriented facilities (parks, retail corridors, work places, etc.) will require interim connections and streetscape improvements. Determine the need for private access drives and mid-block passages.
- » Pedestrian/bicycle connections may be provided through developments prior to build out, or along future private access drives. If connections are provided through developments, consider the appropriate sidewalk widths necessary for the expected pedestrian volumes as well as necessary lighting levels. Avoid dark or unlit areas and areas with blind spots or low-visibility.

- » In phased development plans, consider how pedestrian access will be provided and preserved throughout all stages of development. Consider building sidewalks and streetscapes prior to future building phases so that pedestrian/bicycle access can be enhanced.
- » Design interim connections to be expanded, enhanced, or reconfigured upon completion of future phases of development. This may include widening sidewalks for a final streetscape or integrating a pathway into a future public open space. Consider implementing pedestrian/bicycle facilities in earlier phases so that pedestrians can take advantage of furnishings such as benches and bicycle racks.
- » Some connections to Metro may be temporary in nature because they are adjacent to parcels that have not rezoned, or are later phases of the same project which have not yet been built. In these cases, the interim standards may be appropriate for construction of a consistent, safe, and pleasant pedestrian experience.

# Open Spaces

Green space or park-like open spaces may also evolve over time as land bays are phased and as collective efforts to create the open space network are assembled. Additionally, some open spaces will be built on structures and could be partially phased with the associated structures. There will also be opportunities for interim open space to be constructed on a site where a future building or access drive may be planned as a later phase. In any case, interim open spaces should include fundamental elements such as, but not limited to, the following:

- » Create a physical sense of enclosure while providing visual access into and out of the space.
- » Create multiple, clearly visible entrances to the space.
- » Include planted and hardscape elements.
- » Create places to rest, play and socialize.
- » Where appropriate, use high-quality amenities such as benches, trash receptacles, lighting and play equipment. Avoid viewing the amenities as temporary, even though the site conditions may be temporary.
- » Ensure that site grades and surfaces allow ADA accessibility into and through the open space.
- » For open spaces on structures, ensure that safe and attractive edges, guardrails or parapets are included in the design.
- » Incorporate low-cost, interim planting strategies such as perennial and shrub plantings to create visual interest.
- » Where interim open space conditions are expected to remain less than five years, consider planting and maintaining trees in a manner that they may be relocated to final locations in an ultimate park design or to other appropriate locations in the HTOC.

- » Where interim open space conditions are expected to remain less than five years and relocation of trees appears infeasible, an alternative approach is to consider structures in lieu of trees to provide shade and shelter.
- » Include a maintenance plan for the interim open space that includes all hard surfaces, planted areas, amenities and snow removal.
- » Include design concepts for any interim open space elements in the phasing plans section of the development plan and include detailed open space park design details in the site plan.
- » Signage regarding the interim nature of the facility should also be provided.

# Interim Building Design

Many buildings will be part of a phased development strategy and may include partial buildings or architectural elements that will be built before an ultimate design is realized. In such a scenario, a creative interim design for all facades that interface with the pedestrian realm should be implemented such that an interesting and varied facade is created. It is expected that the building and site design ideas detailed elsewhere in these Guidelines will apply to interim conditions. If certain elements of the design are approved as a temporary condition to be removed during later phases of construction, temporary or less costly materials and construction methods may be considered for those elements.

Any new proposed building must be designed to respond not only to the immediately proposed development plan conditions, but also to future street improvements, private access drives and streetscapes that are envisioned in the Herndon Transit-Oriented Core Plan. Examples of such interim design are:

- » Consider monumental art pieces or other façade applications as interim conditions for partially constructed buildings or parking garages.
- » For interim conditions, design buildings for ultimate build-out by including appropriately scaled entrances and façade articulation to each building face as determined by the ultimate use of the frontage.

# Storm Water Management

As the Transit-Oriented Core develops, the storm water infrastructure will evolve as well. The storm water system should be designed to manage interim conditions as well as anticipate how the individual facilities will function as part of an integrated system at ultimate build-out. Storm water mitigation must meet the Town's regulations and requirements which may change over time in response to new state and federal regulations. Facilities must be designed to manage storm water runoff for major storms as well as more frequently occurring events while protecting water quality, preventing flooding and property damage, and preventing impacts on receiving streams during and after construction.

In addition, detention ponds, storm water vaults and other infrastructure are all form-giving elements to storm water remediation that must be considered in phasing plans in interim conditions. These features must be integrated into an overall development plan and in consideration of phasing.

- » Any interim storm water detention surface ponds should be designed such that they are integrated into an interim landscape as a visual amenity and part of a highly designed landscape. This should include plantings, stonework, paths, benches and lighting.
- » Where storm water storage is contained beneath the interim streetscape, all access points and/or manholes should be placed outside the sidewalk zone.

# Construction and Staging

Construction sites are inevitable as the Transit-Oriented Core is redeveloped and a state of disturbance to the pedestrian realm is to be expected. The use of creative screening, scaffolding and other techniques will minimize the impact of this disturbance.

- » Ensure that a contiguous, safe pedestrian path is provided at all times during construction. This is especially important along primary pedestrian zones including approaches to the Metro pavilion.
- » Consider construction site screening concepts early.
- » Consider cladding construction fence in public art pieces, photographs of renderings of future development or other aesthetic elements.
- » Incorporate temporary lighting elements that illuminate the pedestrian way in all construction site screening and scaffolding.
- » Confirm that temporary construction elements do not block site lines for vehicles at intersections or create low-visibility locations that may be unsafe for pedestrians.
- » Coordinate with the Town to appropriately locate temporary construction yards and related activities so that their impacts on surrounding residents and businesses, as well as with the travel network, can be minimized.

SECTION H

SIGNAGE GUIDELINES





TO BE ADDED AT THE TOWN'S REQUEST AT A LATER DATE



SECTION I

GLOSSARY

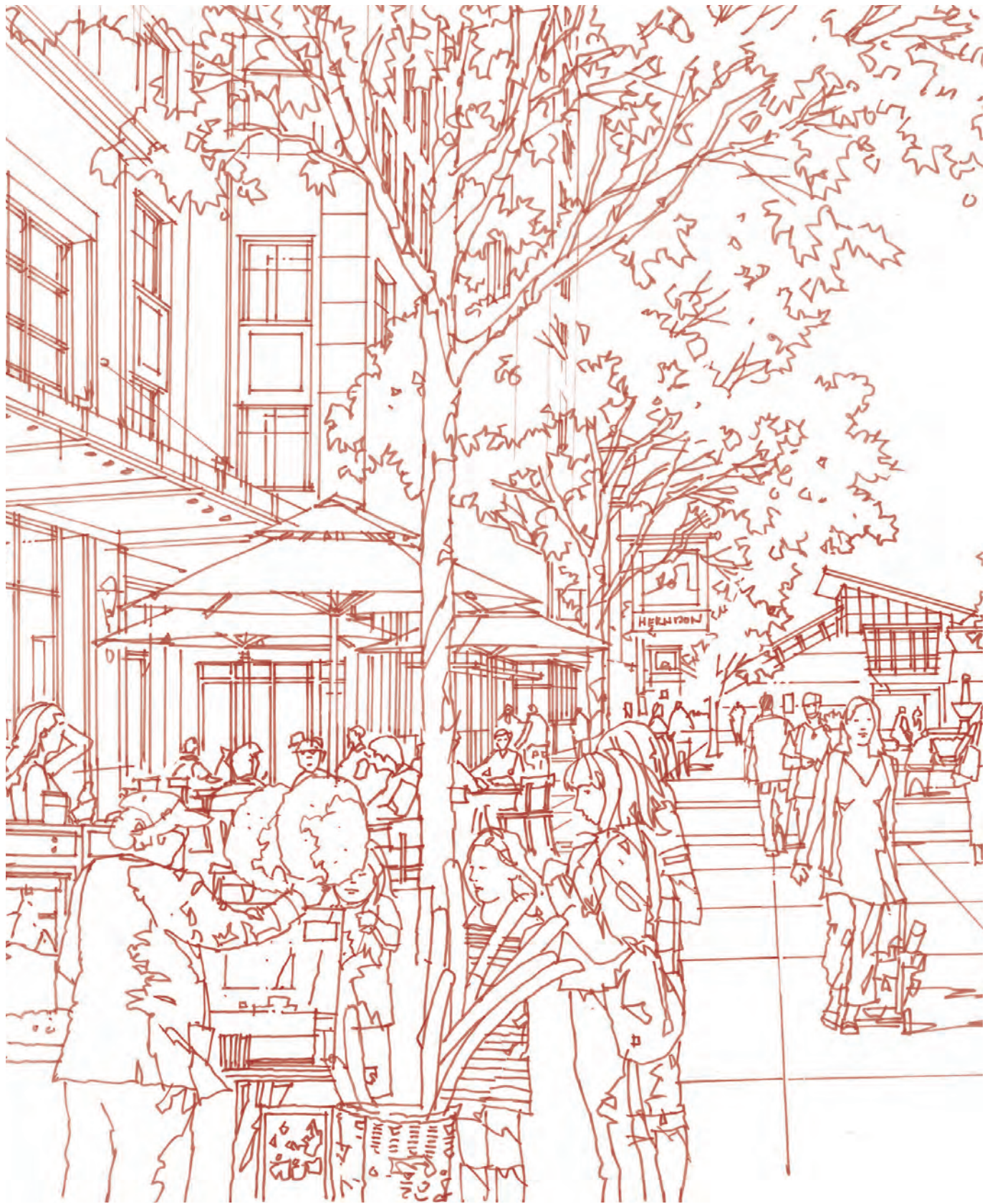

**ACCESS DRIVE, PRIVATE**

Drives built on private development parcels to provide vehicular and bicycle access, accommodate utilities and provide pedestrian connectivity.

**ADDRESS**

Address describes the relationship between the public and private realm and is informed by the character of the architecture, the landscape, and street type the building fronts onto.

**BELT COURSE**

A continuous row or layer of stones, tile, brick, shingles, etc. in a wall

**CLERESTORY**

High windows above eye level to bring outside light, fresh air, or both into the inside of a structure.

**CORNICE**

A projecting molding that tops the elements to which it is attached; used especially for a roof or the crowning member of an entablature, located above the frieze.

**CYCLE TRACKS**

Separated bicycle facilities that run alongside a roadway. Cycle tracks are typically separated from automobile traffic by a physical barrier, such as parked cars, bollards, a landscaped buffer, or a curb. In Herndon a two-way cycle track is planned as part of the streetscape on the south side of Herndon Parkway from Van Buren Street (south) to Spring Street (east).

**FLOOR AREA RATIO**

The ratio of a building's total floor area (Gross Floor Area) to the size of the lot upon which it is built.

**HERNDON METRO STATION AREA PLAN**

Comprehensive Plan Amendment #11-02, adopted by resolution of the Herndon Town Council on February 28, 2012. Includes the Herndon Metro Station Area Study, prepared by VHB, as well as various amendments to the text and maps of the Herndon 2030 Comprehensive Plan.

**HERNDON METRO STATION AREA STUDY**

A document prepared for the Town by VHB and analyzing the area within Herndon on the north side of the Herndon Metro Station for future redevelopment opportunities. Incorporated by reference in Comprehensive Plan Amendment #11-02, adopted by resolution of the Herndon Town Council on February 28, 2012.

**HERNDON TRANSIT-ORIENTED CORE PLAN**

Chapter Six of the Herndon Metro Station Area Study. Includes an illustrative urban design plan as well as principles and guidelines for Metro passenger drop-off, focal points, block size, massing, building facades, parking garages, sustainability, open space and public space.

**KICK PLATE**

Protective plate placed at the bottom of a door

**MEDALLION**

An oval or circular motif typically used as decoration

**MID-BLOCK PASSAGE**

Well designed public space that provide access through development blocks for pedestrians and cyclist.

**NEIGHBORHOOD**

An area of a community with characteristics that distinguish it from other community areas and where commercial and residential tenants share a common identity focused around one or more features such as local heritage, noteworthy section of landscape (e.g., a lake), a transit station, school, park, business center, community facility or other prominent distinction.

**OPEN SPACE**

Exterior space that may include landscaped areas, parks, plazas, trails, buffer areas and other natural areas.

**PIER**

Sections of structural walls between openings (bays)

**PILASTER**

An engaged pier or pillar, often with capital and base

**PLINTH**

A platform base supporting a column or pilaster.

**PODIUM**

A distinct base section, either spread out at the foot of a building or holding entirely different internal areas which is clearly differentiated from the spaces above it by its physical form or by the type of space inside it.

**PUBLIC OPEN SPACE**

Exterior space designed for public access and activities.

**PUBLIC SPACE**

Space designed for public access and activities.

**SIDEWALK**

Pedestrian walkway adjacent to a street.

**STREET**

For purposes of these Guidelines, “streets” are Herndon Parkway, Worldgate Drive Extension, Van

Buren Street and other public streets existing at the time of adoption of the Herndon Transit-Oriented Core Plan.

**STREETSCAPE**

Design of the right-of-way or designated street space including the street, sidewalks, landscape, exterior furnishings and special elements.

**SIGNAGE BAND**

The flat, horizontal area on the facade usually located immediately above the storefront and below the second story window sill where signs were historically attached. A sign band may also occur within a decorative band course above a storefront.

**STOREFRONTS**

The facade of a store at the street level of a building; typically a combination of operational doors and windows.

**TRAIL**

Path intended for non-motorized mobility including pedestrians and cyclists.

**TRANSOM**

1. A horizontal bar of wood or stone across a window. 2. The cross-bar separating a door from the window, panel, or fanlight above it. 3. The window above the transom bar of a door. 4. The glazed area above a display window or door separated from the main window area or door by a transom bar.

APPENDIX

SOLAR STUDIES



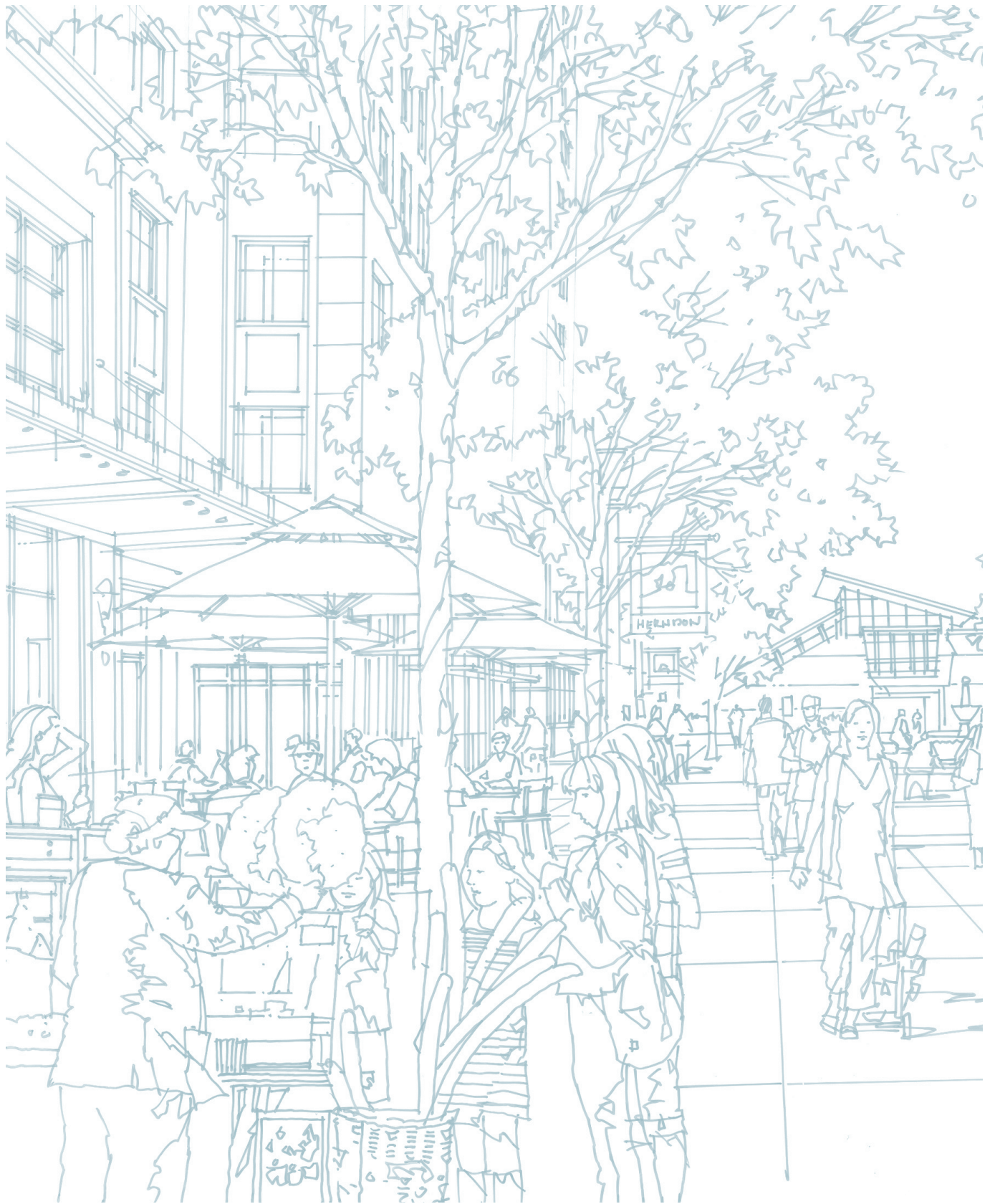

9:00 AM



12:00 PM



3:00 PM



## DESIGN PRINCIPLES

- » Design spaces that maximize sunlight and create pleasant spaces to enjoy the outdoors at appropriate times of the year
- » Avoid streets and spaces that remain in shadow a large part of the year
- » Maximize sun exposure along the Promenade to enhance pedestrian activities
- » Avoid the “canyon” effect along the Promenade that links to the Metro

*(left) Sun and shade studies during the Equinox at 9am, 12pm, and 3pm*

9:00 AM



12:00 PM



3:00 PM



## SUMMER

- » The Promenade is shaded during the morning hours, yet gets full sun at lunch time
- » Solar orientation and shadows should be considered when locating towers

*(left) Sun and shade studies during the Summer at 9am, 12pm, and 3pm*

Published for Town of Herndon, Virginia

© Copyright 2015 Urban Design Associates

All Rights Reserved. No part of this publication may be reproduced or transmitted in any form or by any means, electronic or mechanical, including photocopy or any other information storage and retrieval system, without prior permission in writing from the Town of Herndon or the publisher.

Photographs provided by: LaQuatra Bonci Associates and  
Urban Design Associates